



ITT

ROBOT PUMPS

Vortex pump

RW2122DG

50 Hz

The vortex impeller pumps are designed to pump a wide variety of solids contaminated liquids in many applications. Vortex pumps are used for sewage and other waste water applications. Hydraulic components are available in special materials.

Pump

solids passage : 65 mm
 suction diameter : 72 mm
 discharge diameter : 65 mm
 impeller diameters : 210-190 mm
 recommended min. flow : 2 l/s (8 m³/h)

Motor

rated shaft power : 3.5 kW
 rated electrical power : 4.5 kW
 mains : 50 Hz - 3 phase
 nominal speed : 1450 rpm
 rated efficiency : 78 %
 rated power factor (cos phi) : 0.84
 degree of protection : IP 68
 isolation class : H (180 °C)
 max. water temperature : 40 °C
 (higher temperatures on request)
 standard cable length : 10 m

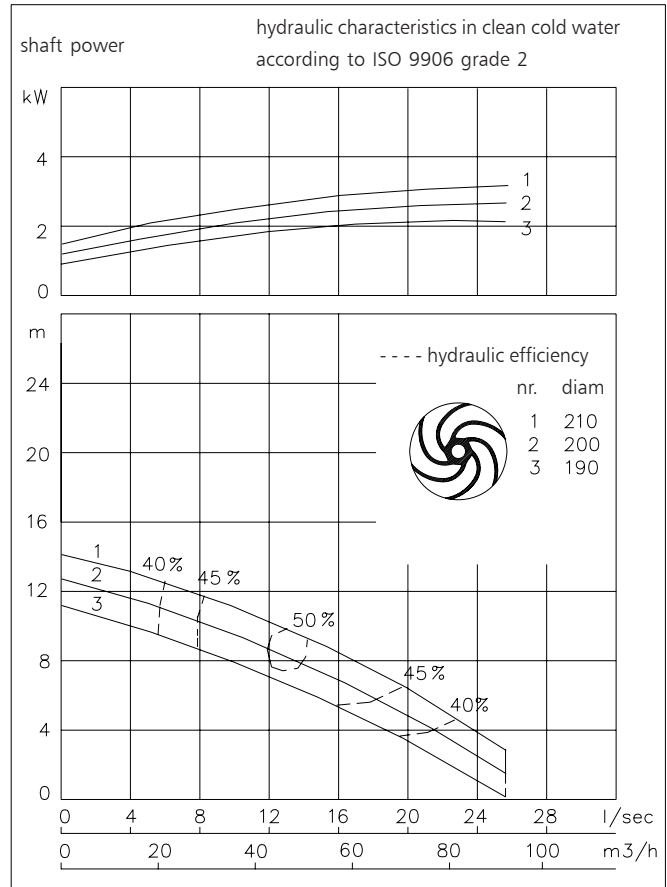

Pump curves are for cast iron only.

Materials

motor housing : 1
 seal housing : 1
 volute : 1 5 6
 impeller : 2 5 6
 shaft : 3 5
 bolts : 4 5

elastomers : 8+9 10
 electrical cable : 9
 seal lubrication : oil
 pump seal : silicon carbide-silicon carbide
 motor seal : carbon-ceramic
 primer : Alkyd primer
 top coating : Two component high-build polyurethane coating

1	cast iron	EN-GJL-250
2	sg cast iron	EN-GJS-400-15
3	stainless steel 431	X20 CrNi 17 2
4	stainless steel 304	X5 CrNi 18 10
5	stainless steel 316	X5 CrNiMo 17 12 2
6	stainless steel 329	X4 CrNiMoN 27 5 2
7	wear resistant sg iron	HB 500
8	nitrile	(NBR)
9	neoprene	(CR)
10	viton	(FPM)
11	Nihard 4	G-X300CrNiSi 9 5 2

www.robotpumps.com

Engineered for life



ITT

ROBOT PUMPS

Installation options

RW2122DG

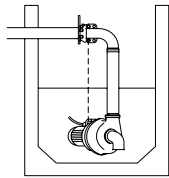

H

Header coupling:
Type HK65 or HK80

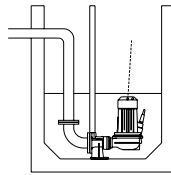

V

Guide bar coupling:
Type V65 or V80

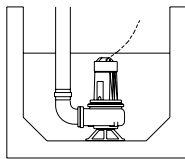
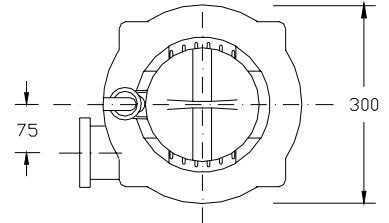

F

Freestanding:
With support and
75mm hose adapter
or G3" threaded
connection

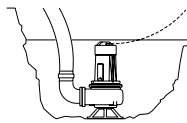

T

Transportable:
With support and
75mm hose adapter
or G3" threaded
connection

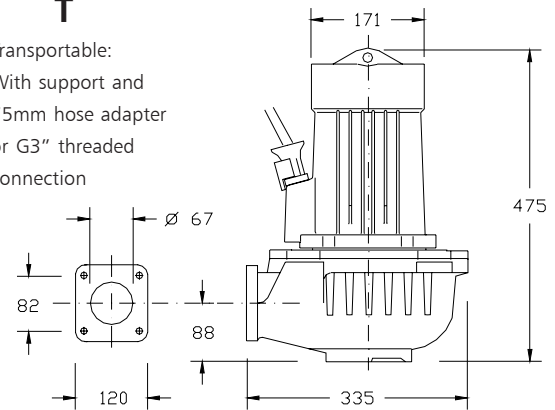

The motor is cooled by the surrounding water.

Version

Weight

B Basic

89 kg

Optional:

Thermoswitches in motorwindings

Flexible protective sheathing for cable
(AISI 316)

Water detector in motor and oil housing

Motor connection details

voltage [V]*	rated current[A]	number of cables x number of cores x cross section [mm²]			
		without waterdetector and/or thermoswitches		with waterdetector and/or thermoswitches	
		DOL-start	YD-start	DOL-start	YD-start
220	14.0	1x4x2.5	1x7x1.5	1x7x1.5	1x10x1.5
380	8.1	1x4x2.5	1x7x1.5	1x7x1.5	1x10x1.5
400	7.7	1x4x2.5	1x7x1.5	1x7x1.5	1x10x1.5
415	7.4	1x4x2.5	1x7x1.5	1x7x1.5	1x10x1.5
500	6.2	1x4x2.5	1x7x1.5	1x7x1.5	1x10x1.5

starting current DOL-start : 4.3 x rated current

* other voltages on request

starting current YD-start : 1.4 x rated current

We reserve the right to alter specifications without prior notice.