



Vortex Pump

RW2110BE

60 c/s

The vortex impeller pumps are designed to pump a wide variety of solids contaminated liquids in many applications. Vortex pumps are used for sewage and other waste water applications. Hydraulic components are available in special materials.

Pump

solids passage : 2"
 suction diameter : 2"
 discharge diameter : 2"
 impeller code : 118-95
 recommended minimum flow : 24 USGPM

Motor

rated horse power : 4.0 hp
 rated electrical power : 4.0 kW
 rated kVA : 4.4 kVA
 mains : 60 c/s
 speed : 3500 rpm
 rated efficiency : 75 %
 rated power factor (cos phi) : 0.90
 degree of protection : IP 68
 isolation class : F (311 °F)
 max. water temperature : 104 °F
 (higher temperatures on request)
 standard cable length : 33 ft
 max. submersion depth : 66 ft

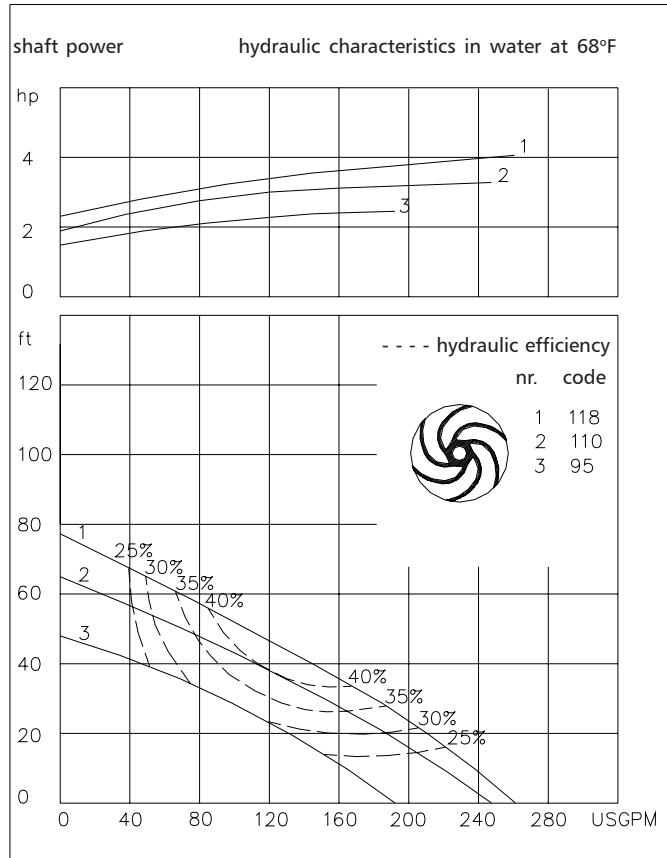

Pump curves are for cast iron only.

15.9 USGPM = 1 l/s 1 hp = 0.746 kW 1 ft = 0.3 m 1 lb = 0.45 kg

Materials

motor housing : 1
 seal housing : 1
 volute : 1 5
 impeller : 2 5 6
 shaft : 3 5
 bolts : 4 5

elastomers : 8+9 10
 electrical cable : 9
 seal lubrication : oil
 pump seal : silicon carbide-silicon carbide
 motor seal : carbon-ceramic
 primer : Alkyd primer
 top coating : Two component high-build polyurethane coating

1	cast iron	ASTM A-48 Cl.35
2	sg cast iron	ASTM A445 Gr.60-46-18
3	stainless steel	AISI 431
4	stainless steel	AISI 304
5	stainless steel	AISI 316
6	stainless steel	AISI 329
7	wear resistant sg iron	HB500
8	nitrile	(NBR)
9	neoprene	(CR)
10	viton	(FPM)



ITT

ROBOT PUMPS

Installation options

RW2110BE

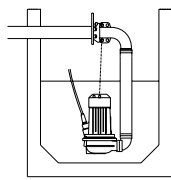

H
Header coupling:
Type HK65 or HK80

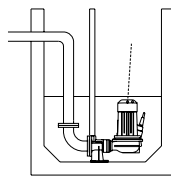

V
Guide bar coupling:
Type V50

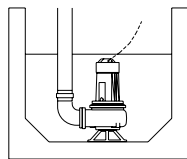
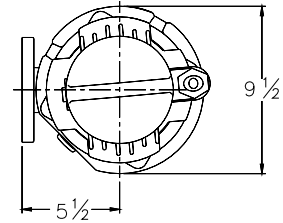

F
Freestanding:
With support and
2" or 3" hose adapter
or NPT threaded
connection

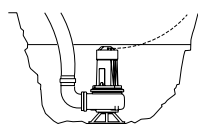

T
Transportable:
With support and
2" or 3" hose adapter
or NPT threaded
connection

The motor is cooled by the surrounding water.

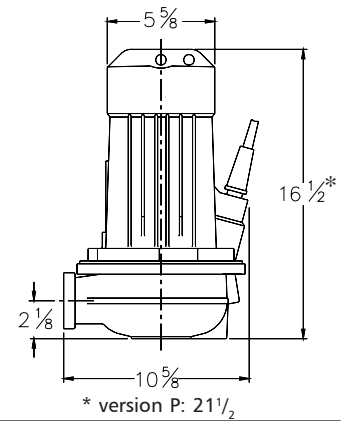
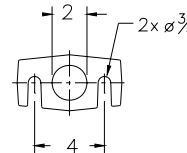

Versions

Weight

B Basic version

95 lbs

P FM approved version

121 lbs

Certified according to:
Class I, Division I, Groups C&D T4
Standard with thermostats and
waterdetector in motorhousing.

Optional:

Thermostiches in motorwindings
Standard for FM approved version

Flexible protective sheathing for cable
(AISI 316)

Water detector in motor and oil housing (for flame proof version only in oil housing with external cable)

Motor connection details

voltage [V]*	rated current[A]	electrical cable size					
				with waterdetector and/or thermostiches		FM approved version	
		DOL-start	YD-start	DOL-start	YD-start	DOL-start	YD-start
220	11.7	1xAWG14/4	1xAWG16/7	1xAWG14/7	1xAWG16/10	1xAWG14/8	1xAWG14/12
380	6.8	1xAWG16/4	1xAWG16/7	1xAWG16/7	1xAWG16/10	1xAWG14/8	1xAWG14/12
440	5.9	1xAWG16/4	1xAWG16/7	1xAWG16/7	1xAWG16/10	1xAWG14/8	1xAWG14/12
460	5.6	1xAWG16/4	1xAWG16/7	1xAWG16/7	1xAWG16/10	1xAWG14/8	1xAWG14/12
575	4.5	1xAWG16/4	1xAWG16/7	1xAWG16/7	1xAWG16/10	1xAWG14/8	1xAWG14/12

starting current DOL-start : 4.6 x rated current

* other voltages on request

starting current YD-start : 1.5 x rated current

We reserve the right to alter specifications without prior notice.