



Vortex Pump

RW2110BH

60 c/s

The vortex impeller pumps are designed to pump a wide variety of solids contaminated liquids in many applications. Vortex pumps are used for sewage and other waste water applications. Hydraulic components are available in special materials.

Pump

solids passage : 2"
 suction diameter : 2"
 discharge diameter : 2"
 impeller code : 138-118
 recommended minimum flow : 24 USGPM

Motor

rated horse power : 6.2 hp
 rated electrical power : 5.6 kW
 rated kVA : 6.6 kVA
 mains : 60 c/s
 speed : 3500 rpm
 rated efficiency : 82 %
 rated power factor (cos phi) : 0.85
 degree of protection : IP 68
 isolation class : F (311 °F)
 max. water temperature : 104°F
 (higher temperatures on request)
 standard cable length : 33 ft
 max. submersion depth : 66 ft

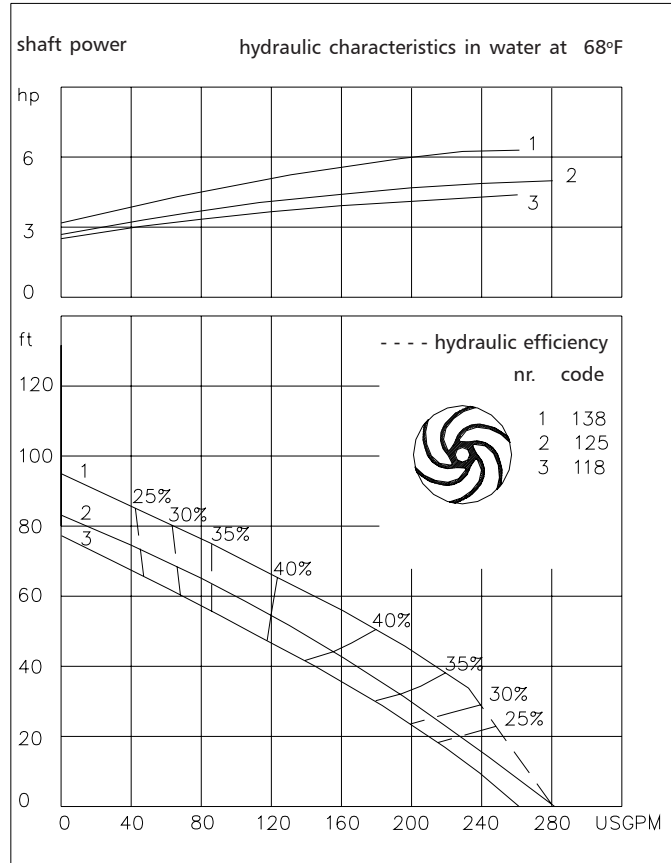

15.9 USGPM = 1 l/s 1 hp = 0.746 kW 1 ft = 0.3 m 1 lb = 0.45 kg

Materials

motor housing	: 1
seal housing	: 1 5
volute	: 1 5
impeller	: 2 5 6
shaft	: 3 5
bolts	: 4 5
elastomers	: 8+9 10
electrical cable	: 9
seal lubrication	: oil
pump seal	: silicon carbide-silicon carbide
motor seal	: carbon-ceramic
primer	: Alkyd primer
top coating	: Two component high-build polyurethane coating

1	cast iron	ASTM A-48 Cl.35
2	sg cast iron	ASTM A445 Gr.60-46-18
3	stainless steel	AISI 431
4	stainless steel	AISI 304
5	stainless steel	AISI 316
6	stainless steel	AISI 329
7	wear resistant sg iron	HB500
8	nitrile	(NBR)
9	neoprene	(CR)
10	viton	(FPM)



ITT

ROBOT PUMPS

Installation options

RW2110BH

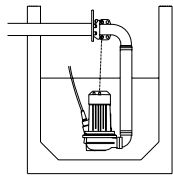

H
Header coupling:
Type HK65 or HK80

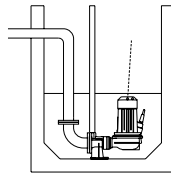

V
Guide bar coupling:
Type V50

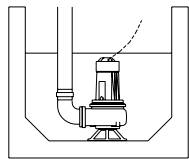
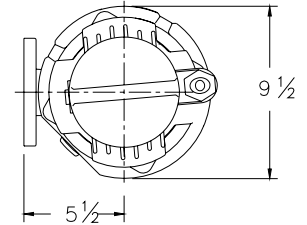

F
Freestanding:
With support and
2" or 3" hose adapter
or NPT threaded
connection

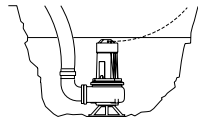

T
Transportable:
With support and
2" or 3" hose adapter
or NPT threaded
connection

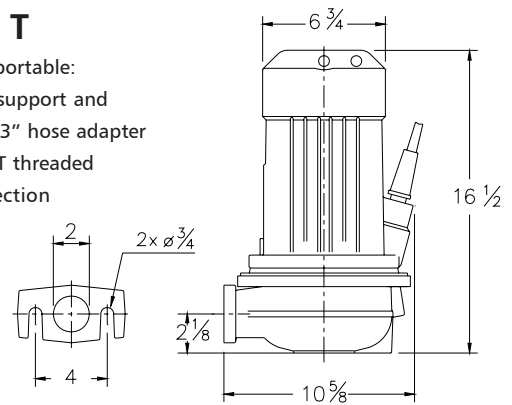

The motor is cooled by the surrounding water.

Versions

Weight

B Basic version

95 lbs

Optional:

Thermoswitches in motorwindings

Flexible protective sheathing for cable
(AISI 316)

Water detector in motor and oil housing

Motor connection details

voltage [V]*	rated current[A]	number of cables x number of cores x cross section [mm ²]					
		DOL-start	YD-start	with waterdetector and/or thermoswitches			
				DOL-start	YD-start		
220	17.3	1xAWG12/4	1xAWG16/7	-	-		
380	10.0	1xAWG14/4	1xAWG16/7	1xAWG16/7	1xAWG16/10		
440	8.7	1xAWG16/4	1xAWG16/7	1xAWG16/7	1xAWG16/10		
460	8.3	1xAWG16/4	1xAWG16/7	1xAWG16/7	1xAWG16/10		
575	6.6	1xAWG16/4	1xAWG16/7	1xAWG16/7	1xAWG16/10		

starting current DOL- start : 6.2 x rated current

* other voltages on request

starting current YD- start : 2.1 x rated current

We reserve the right to alter specifications without prior notice.