



ITT

ROBOT PUMPS

Vortex Pump

RW2120BB

60 c/s

The vortex impeller pumps are designed to pump a wide variety of solids contaminated liquids in many applications. Vortex pumps are used for sewage and other waste water applications. Hydraulic components are available in special materials.

Pump

solids passage : 2 1/2"
 suction diameter : 2 1/2"
 discharge diameter : 2 1/2"
 impeller code : 95 - 80
 recommended minimum flow : 32 USGPM

Motor

3 phase

rated horse power : 2.3 hp
 rated electrical power : 2.4 kW
 rated kVA : 2.6 kVA
 mains : 60 c/s
 speed : 3500 rpm
 rated efficiency : 69 %
 rated power factor (cos phi) : 0.91
 degree of protection : IP 68
 isolation class : F (311 °F)
 max. water temperature : 104 °F
 (higher temperatures on request)
 standard cable length : 33 ft
 max. submersion depth : 66 ft

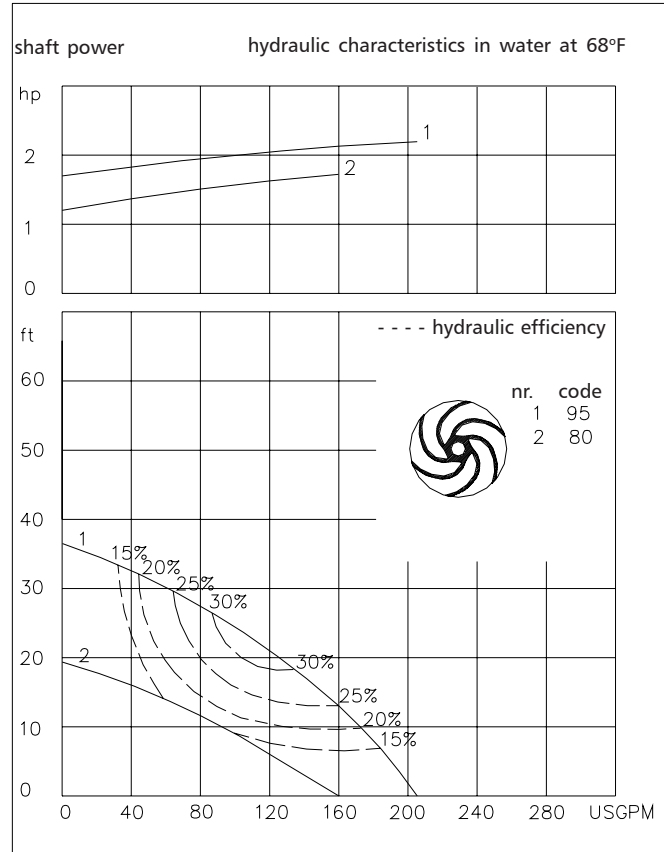

Pump curves are for cast iron only.

15.9 USGPM = 1 l/s 1 hp = 0.746 kW 1 ft = 0.3 m 1 lb = 0.45 kg

Materials

motor housing : 1
 seal housing : 1
 volute : 1 5
 impeller : 2 5 6
 shaft : 3 5
 bolts : 4 5

elastomers : 8+9 10
 electrical cable : 9
 seal lubrication : oil
 pump seal : silicon carbide-silicon carbide
 motor seal : carbon-ceramic
 primer : Alkyd primer
 top coating : Two component high-build polyurethane coating

1	cast iron	ASTM A-48 Cl.35
2	sg cast iron	ASTM A445 Gr.60-46-18
3	stainless steel	AISI 431
4	stainless steel	AISI 304
5	stainless steel	AISI 316
6	stainless steel	AISI 329
7	wear resistant sg iron	HB500
8	nitrile	(NBR)
9	neoprene	(CR)
10	viton	(FPM)

www.ittwalphen.com

Engineered for life



ITT

ROBOT PUMPS

Installation options

RW2120BB

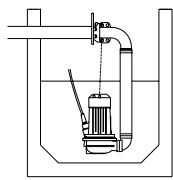

H
Header coupling:
Type HK65 or HK80

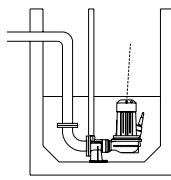

V
Guide bar coupling:
Type V65 or V80

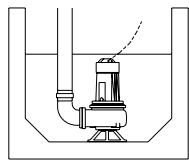
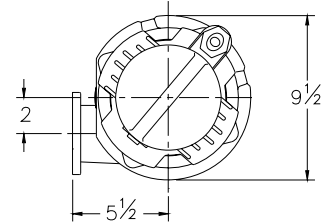

F
Freestanding:
With support and
3" hose adapter
or NPT threaded
connection

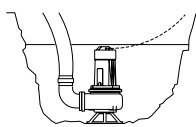

T
Transportable:
With support and
3' hose adapter
or NPT threaded
connection

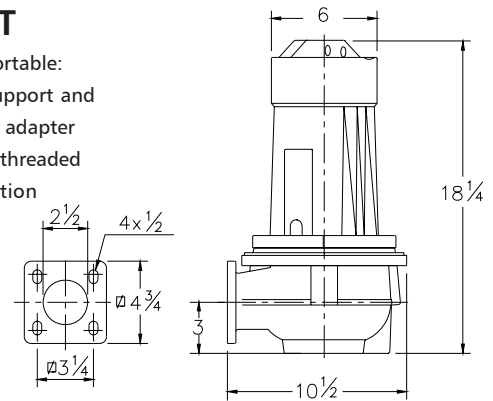

The motor is cooled by the surrounding water.

Versions

Weight

B Basic version (3 phase)

79 lbs

Optional:

Thermoswitches in motorwindings

Flexible protective sheathing for cable
(AISI 316)

Water detector in motor and oil housing

Motor connection details

voltage [V]*	rated current[A]	number of cables x number of cores x cross section [mm ²]			
		DOL-start		with waterdetector and/or thermoswitches	
220	6.9	1xAWG16/4		1xAWG16/7	
380	4.0	1xAWG16/4		1xAWG16/7	
440	3.5	1xAWG16/4		1xAWG16/7	
460	3.3	1xAWG16/4		1xAWG16/7	
575	2.6	1xAWG16/4		1xAWG16/7	

starting current DOL-start : 4.8 x rated current

* other voltages on request

We reserve the right to alter specifications without prior notice.