



ITT

ROBOT PUMPS

Vortex Pump

RW2122DG

60 c/s

The vortex impeller pumps are designed to pump a wide variety of solids contaminated liquids in many applications. Vortex pumps are used for sewage and other waste water applications. Hydraulic components are available in special materials.

Pump

solids passage : 2 1/2"
 suction diameter : 2 7/8"
 discharge diameter : 2 1/2"
 impeller code : 195-165
 recommended minimum flow : 32 USGPM

Motor

rated horse power : 5.4 hp
 rated electrical power : 5.2 kW
 rated kVA : 6.1 kVA
 mains : 60 c/s - 3 phase
 speed : 1750 rpm
 rated efficiency : 77 %
 rated power factor (cos phi) : 0.85
 degree of protection : IP 68
 isolation class : F (311 °F)
 max. water temperature : 104 °F
 (higher temperatures on request)
 standard cable length : 33 ft
 max. submersion depth : 66 ft

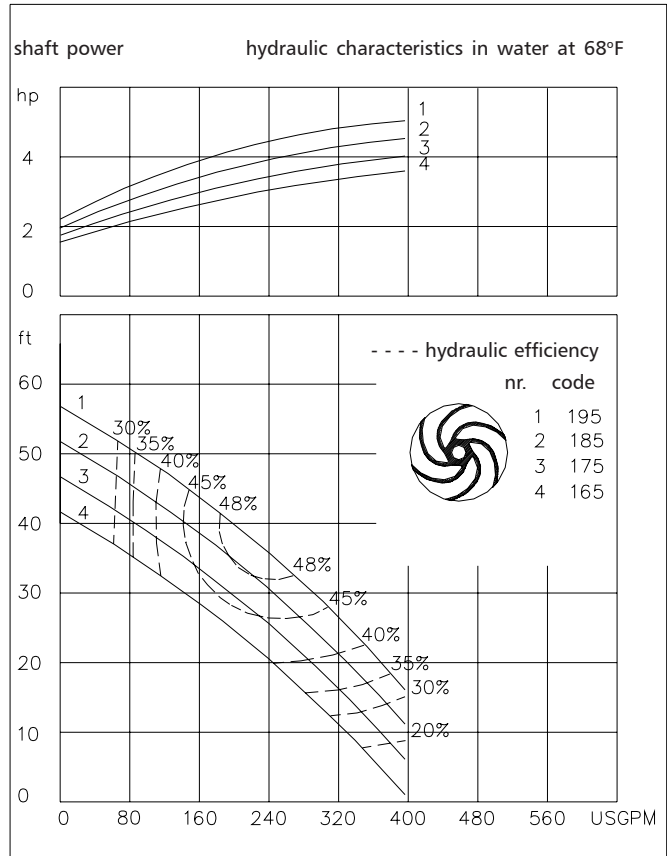

Pump curves are for cast iron only.

15.9 USGPM = 1 l/s 1 hp = 0.746 kW 1 ft = 0.3 m 1 lb = 0.45 kg

Materials

motor housing : 1
 seal housing : 1
 volute : 1 5
 impeller : 2 5 6
 shaft : 3 5
 bolts : 4 5

elastomers : 8+9 10
 electrical cable : 9
 seal lubrication : oil
 pump seal : silicon carbide-silicon carbide
 motor seal : carbon-ceramic
 primer : Alkyd primer
 top coating : Two component high-build polyurethane coating

1	cast iron	ASTM A-48 Cl.35
2	sg cast iron	ASTM A445 Gr.60-46-18
3	stainless steel	AISI 431
4	stainless steel	AISI 304
5	stainless steel	AISI 316
6	stainless steel	AISI 329
7	wear resistant sg iron	HB500
8	nitrile	(NBR)
9	neoprene	(CR)
10	viton	(FPM)

www.ittwalphen.com

Engineered for life



ITT

ROBOT PUMPS

Installation options

RW2122DG

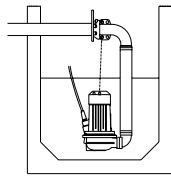

H
Header coupling:
Type HK65 or HK80

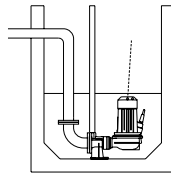

V
Guide bar coupling:
Type V65 or V80

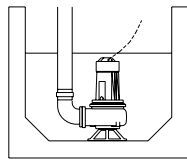
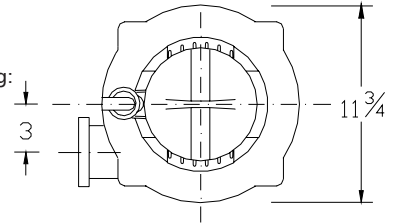

F
Freestanding:
With support and
3" hose adapter
or NPT threaded
connection

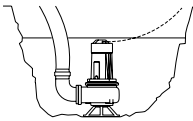

T
Transportable:
With support and
3" hose adapter
or NPT threaded
connection

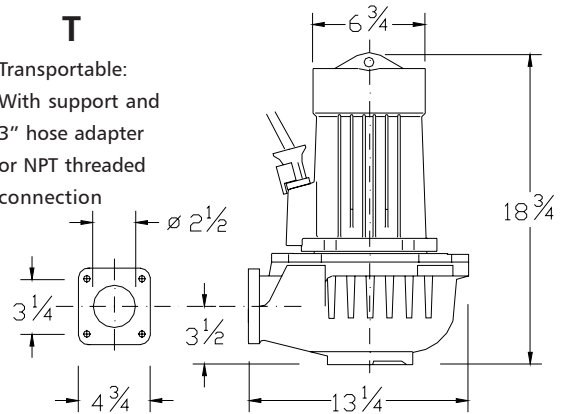

The motor is cooled by the surrounding water.

Versions

Weight

B Basic version

124 lbs

Optional:

Thermoswitches in motorwindings

Flexible protective sheathing for cable
(AISI 316)

Water detector in motor and oil housing

Motor connection details

voltage [V]*	rated current[A]	electrical cable size			
		DOL-start	YD-start	with waterdetector and/or thermoswitches DOL-start	YD-start
220	16.0	1xAWG12/4	1xAWG16/7	not possible	1xAWG16/10
380	9.3	1xAWG14/4	1xAWG16/7	1xAWG16/7	1xAWG16/10
440	8.0	1xAWG14/4	1xAWG16/7	1xAWG16/7	1xAWG16/10
460	7.7	1xAWG14/4	1xAWG16/7	1xAWG16/7	1xAWG16/10
575	6.1	1xAWG14/4	1xAWG16/7	1xAWG16/7	1xAWG16/10

starting current DOL-start : 4.3 x rated current

starting current YD-start : 1.4 x rated current

* other voltages on request

We reserve the right to alter specifications without prior notice.