



ITT

ROBOT PUMPS

Vortex stainless steel pump

RW2112DD

50 Hz

The vortex stainless steel pumps are designed to pump a wide variety of solids contaminated liquids in many applications. Vortex pumps are used for sewage and other waste water applications. The pump can be used in aggressive applications pH = 1-13. Standard elastomers are in FPM (Viton).

Pump

solids passage : 50 mm
 suction diameter : 65 mm
 discharge diameter : 65 mm
 impeller diameters : 160-130 mm
 recommended min. flow : 2 l/s (8 m³/h)

Motor

rated shaft power : 2.2 kW
 rated electrical power : 3.0 kW
 mains : 50 Hz - 3 phase
 nominal speed : 1375 rpm
 rated efficiency : 71 %
 rated power factor (cos phi) : 0.89
 degree of protection : IP 68
 isolation class : H (180 °C)
 max. water temperature : 40 °C
 (higher temperatures on request)
 standard cable length : 10 m

Materials

motor housing : 5 6
 seal housing : 5 6
 volute : 5 6
 impeller : 5 6
 shaft : 5
 bolts : 5

elastomers : 10
 electrical cable : 9
 seal lubrication : oil
 pump seal : silicon carbide-silicon carbide
 motor seal : carbon-ceramic

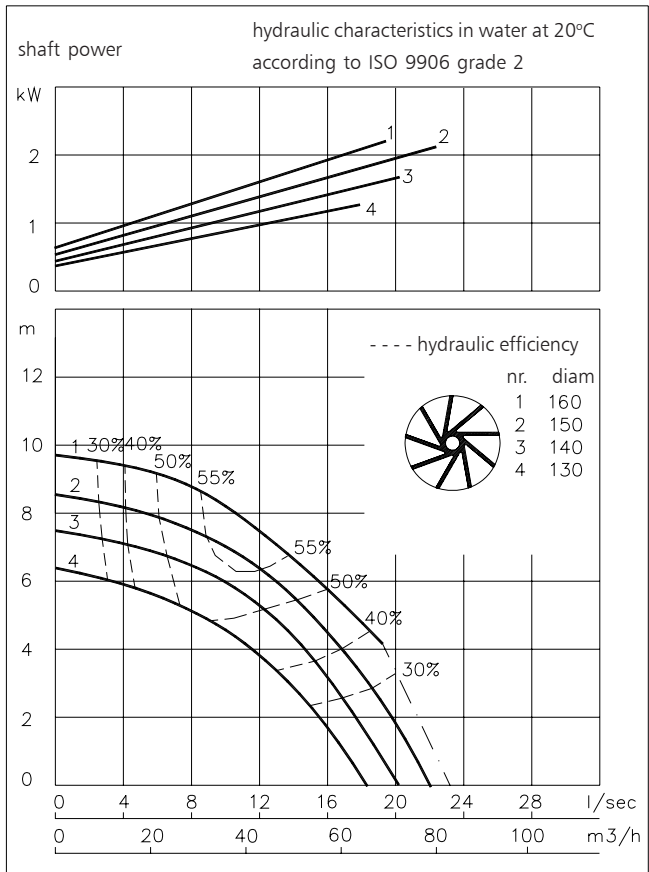

1	cast iron	EN-GJL-250
2	sg cast iron	EN-GJS-400-15
3	stainless steel 431	X20 CrNi 17 2
4	stainless steel 304	X5 CrNi 18 10
5	stainless steel 316	X5 CrNiMo 17 12 2
6	stainless steel 329	X4 CrNiMoN 27 5 2
7	wear resistant sg iron	HB 500
8	nitrile	(NBR)
9	neoprene	(CR)
10	viton	(FPM)
11	Nihard 4	G-X300CrNiSi 9 5 2

www.robotpumps.com

Engineered for life



Installation options

RW2112DD

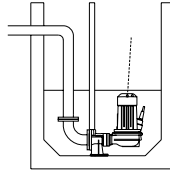

V

Guide bar coupling:
Type V65 or V80

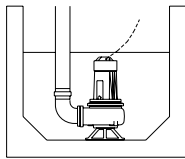
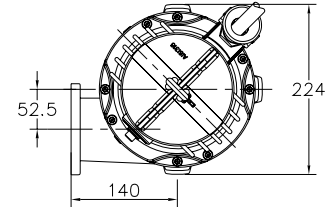

F

Freestanding:
With support and
75mm hose adapter
or G3" threaded
connection

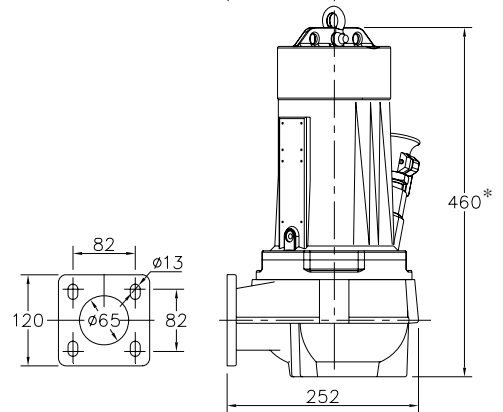

* version ER: 560

The motor is cooled by the surrounding water.

Version

Weight

BR Basic Stainless Steel

Standard with thermostiches
All parts in stainless steel 316

43 kg

BD Basic Duplex Steel

Standard with thermostiches
All casted parts in stainless steel 329

43 kg

ER Explosion proof

Certified according to: II 2 G Ex de IIB c T4
Standard with thermostiches
All parts in stainless steel 316

55 kg

Optional:

Flexible protective sheating for cable
(AISI 316)

Water detector in motor and oil housing
(for explosion proof version only in oil housing with external cable)

Motor connection details

voltage [V]*	rated current[A]	number of cables x number of cores x cross section [mm ²]					
				with waterdetector and/or thermostiches		explosion proof version	
				DOL-start	YD-start	DOL-start	
220	9.1			1x7x2.5	1x10x1.5	1x7x2.5	
380	5.3			1x7x2.5	1x10x1.5	1x7x2.5	
400	5.0			1x7x2.5	1x10x1.5	1x7x2.5	
415	4.8			1x7x2.5	1x10x1.5	1x7x2.5	
500	4.0			1x7x2.5	1x10x1.5	1x7x2.5	

starting current DOL-start

: 3.4 x rated current

* other voltages on request

starting current YD-start

: 1.1 x rated current

We reserve the right to alter specifications without prior notice.