



ITT

ROBOT PUMPS

Vortex stainless steel pump

RW2120BE

60 c/s

The vortex stainless steel pumps are designed to pump a wide variety of solids contaminated liquids in many applications. Vortex pumps are used for sewage and other waste water applications. The pump can be used in aggressive applications pH = 1-13. Standard elastomers are in FPM (Viton).

Pump

solids passage : 2 1/2"
 suction diameter : 2 1/2"
 discharge diameter : 2 1/2"
 impeller code : 118 - 95
 recommended minimum flow : 32 USGPM

Motor

rated horse power : 4.0 hp
 rated electrical power : 4.0 kW
 rated kVA : 4.4 kVA
 mains : 60 c/s - 3 phase
 speed : 3500 rpm
 rated efficiency : 75 %
 rated power factor (cos phi) : 0.90
 degree of protection : IP 68
 isolation class : F (311 °F)
 max. water temperature : 104 °F
 (higher temperatures on request)
 standard cable length : 33 ft
 max. submersion depth : 66 ft

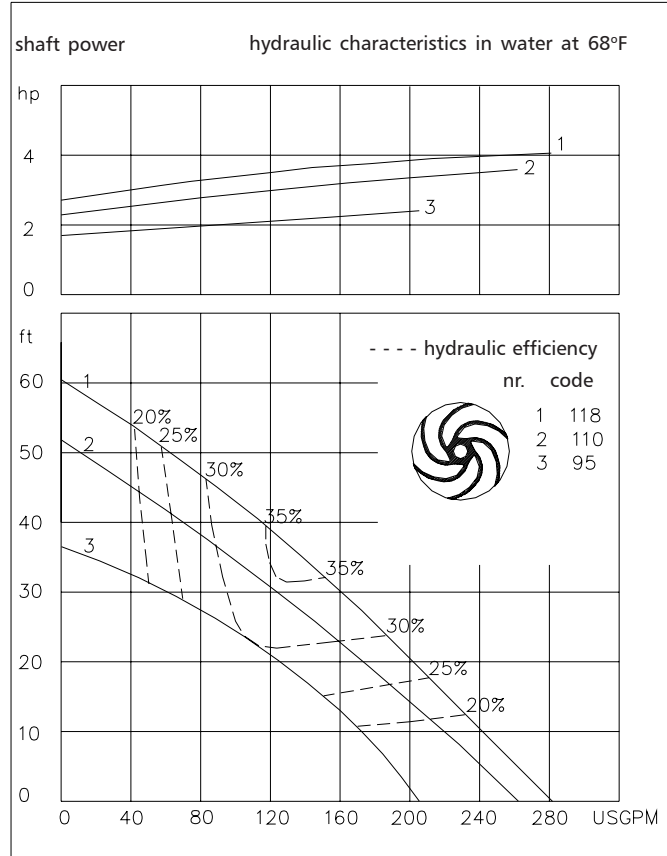

15.9 USGPM = 1 l/s 1 hp = 0.746 kW 1 ft = 0.3 m 1 lb = 0.45 kg

Materials

motor housing : 5 6
 seal housing : 5 6
 volute : 5 6
 impeller : 5 6
 shaft : 5
 bolts : 5

elastomers : 10
 electrical cable : 9
 seal lubrication : oil
 pump seal : silicon carbide-silicon carbide
 motor seal : carbon-ceramic

1	cast iron	ASTM A-48 Cl.35
2	sg cast iron	ASTM A445 Gr.60-46-18
3	stainless steel	AISI 431
4	stainless steel	AISI 304
5	stainless steel	AISI 316
6	stainless steel	AISI 329
7	wear resistant sg iron	HB500
8	nitrile	(NBR)
9	neoprene	(CR)
10	viton	(FPM)

www.ittwalphen.com

Engineered for life



Installation options

RW2120BE

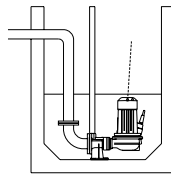

V
Guide bar coupling:
Type V65 or V80

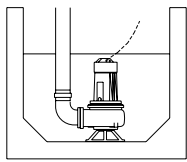
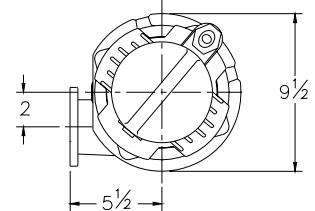

F
Freestanding:
With support and
3" hose adapter
or NPT threaded
connection

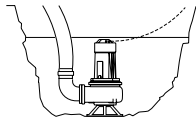

T
Transportable:
With support and
3" hose adapter
or NPT threaded
connection

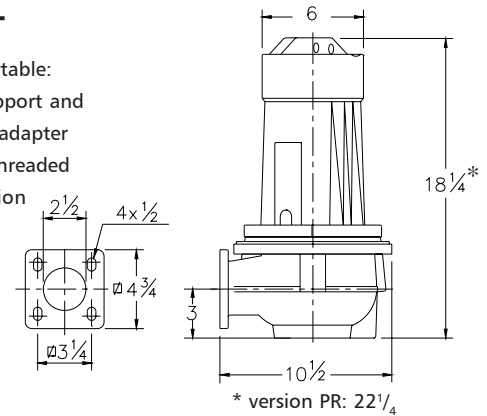

The motor is cooled by the surrounding water.

Versions

Weight

BR Basic Stainless Steel

Standard with thermostiches
All parts in stainless steel 316

95 lbs

BD Basic Duplex Steel

Standard with thermostiches
All casted parts in stainless steel 329

95 lbs

PR FM approved version

Certified according to:
Class I, Division I, Groups C&D T4
Standard with thermostiches
All parts in stainless steel 316

121 lbs

Optional:

Flexible protective sheathing for cable
(AISI 316)

Water detector in motor and oil housing
(for flame proof version only in oil housing with external cable)

Motor connection details

		electrical cable size					
voltage [V]*	rated current[A]			with waterdetector and/or thermostiches		FM approved version	
				DOL-start	YD-start	DOL-start	
220	11.7			1xAWG14/7	1xAWG16/10	1xAWG14/7	
380	6.8			1xAWG14/7	1xAWG16/10	1xAWG14/7	
440	5.9			1xAWG14/7	1xAWG16/10	1xAWG14/7	
460	5.6			1xAWG14/7	1xAWG16/10	1xAWG14/7	
575	4.5			1xAWG14/7	1xAWG16/10	1xAWG14/7	

starting current DOL-start : 4.6 x rated current

starting current YD-start : 1.5 x rated current

* other voltages on request

We reserve the right to alter specifications without prior notice.