



# ITT

## ROBOT PUMPS

### Turbotex Pump

### RT4031DG

### 50 Hz

Turbotex pumps are auto cleaning solids handling pumps. The impeller leading edge is almost parallel with the direction of the flow and leads into the impeller passage. Turbotex pumps are first choice for raw unscreened sewage as well as for lightly contaminated liquids.

#### Pump

solids passage : 78 mm  
 suction diameter : 107 mm  
 discharge diameter : 100 mm  
 impeller diameter : 175 - 145 mm  
 recommended minimum flow : 6 l/s (21 m<sup>3</sup>/h)

#### Motor

rated shaft power : 3.5 kW  
 rated electrical power : 4.5 kW  
 mains : 50 Hz - 3 phase  
 nominal speed : 1450 rpm  
 motor efficiency : 79%  
 rated power factor (cos phi) : 0.73  
 degree of protection : IP 68  
 isolation class : H (180 °C)  
 max. water temperature : 40 °C  
 (higher temp. on request)  
 standard cable length : 10 m

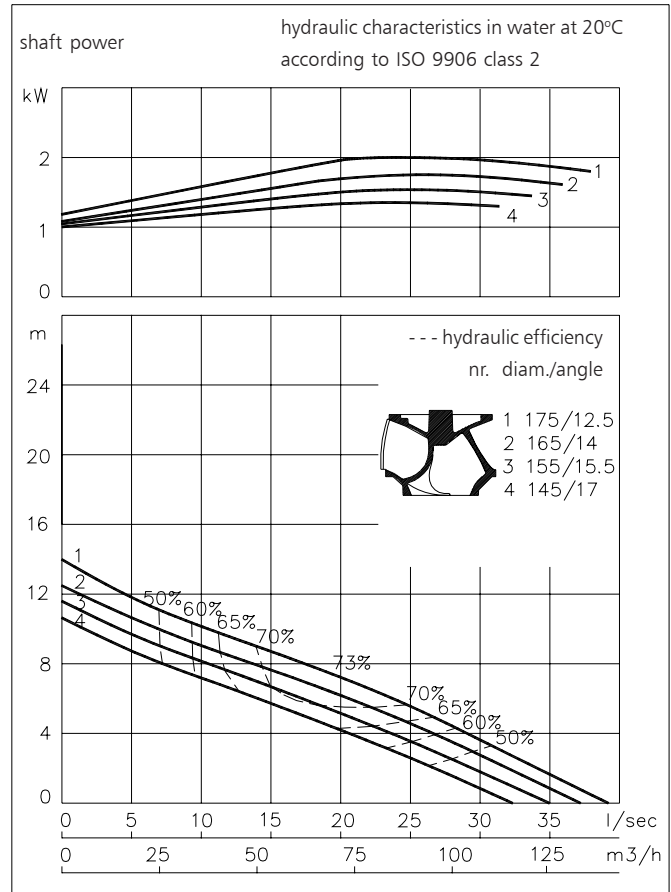

#### Materials

motor housing : 1  
 seal housing : 1  
 volute : 1  
 impeller : 2 7  
 shaft : 3 5  
 bolts : 4 5  
 cooling jacket : 5  
 elastomers : 8+9 10  
 electrical cable : 9  
 seal lubrication : oil  
 pump seal : silicon carbide-silicon carbide  
 motor seal : silicon carbide-silicon carbide  
 primer : Alkyd primer  
 top coating : Two component high-build polyurethane coating

1	cast iron	EN-GJL-250
2	sg cast iron	EN-GJS-400-15
3	stainless steel 431	X20 CrNi 17 2
4	stainless steel 304	X5 CrNi 18 10
5	stainless steel 316	X5 CrNiMo 17 12 2
6	stainless steel 329	X4 CrNiMoN 27 5 2
7	wear resistant sg iron	HB 500
8	nitrile	(NBR)
9	neoprene	(CR)
10	viton	(FPM)

[www.robotpumps.com](http://www.robotpumps.com)

*Engineered for life*



### Installation options

### RT4031DG

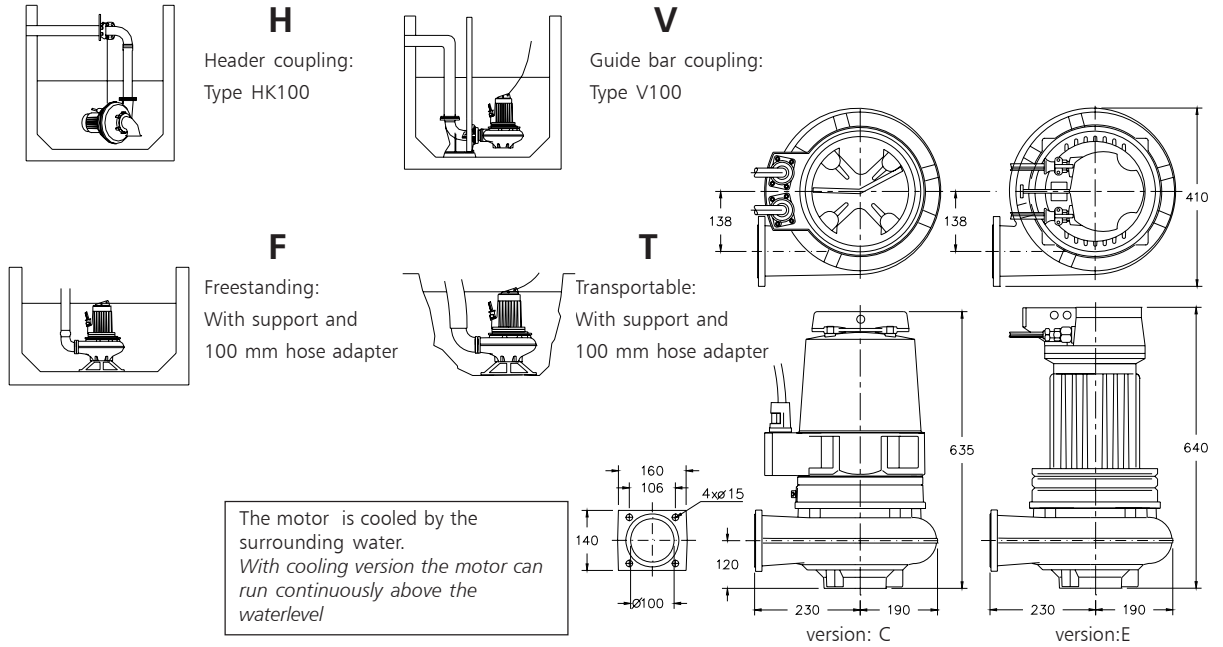

### Versions

- E Explosion proof version**  
Certified according to: II 2 G Ex de IIB c T4  
Standard with 2 sets of thermostiches.
- C Version with cooling system**  
(Not possible for explosion proof version)  
Internal or external circulation  
(external cooling water min. flow 0.15 l/s)

### Weight:

- 106 kg
- 109 kg

### Optional:

- Flexible protective sheathing for cable**  
(AISI 316)
- Water detector in motor and oil housing**  
(for explosion proof version only in oil housing with external cable)

### Motor connection details

voltage [V]*	rated current[A]	number of cables x number of cores x cross section [mm <sup>2</sup> ]					
				with waterdetector and/or thermostiches		explosion proof vevrsion	
		DOL-start	YD-start	DOL- start	YD-start	DOL- start	YD-start
220	16.4	1x4x2.5	1x7x1.5	1x7x2.5	1x10x1.5	1x7x2.5	1x7x2.5 + 1x4x2.5
380	9.5	1x4x2.5	1x7x1.5	1x7x1.5	1x10x1.5	1x7x2.5	1x7x2.5 + 1x4x2.5
400	9.0	1x4x2.5	1x7x1.5	1x7x1.5	1x10x1.5	1x7x2.5	1x7x2.5 + 1x4x2.5
415	8.7	1x4x2.5	1x7x1.5	1x7x1.5	1x10x1.5	1x7x2.5	1x7x2.5 + 1x4x2.5
500	7.2	1x4x2.5	1x7x1.5	1x7x1.5	1x10x1.5	1x7x2.5	1x7x2.5 + 1x4x2.5

starting current DOL start : 6.4 x rated current \* other voltages on request  
 starting current YD-start : 2.1 x rated current We reserve the right to alter specifications without prior notice.