



# ITT

## ROBOT PUMPS

### Turbotex Pump

### RT6040LD

### 50 Hz

Turbotex pumps are auto cleaning solids handling pumps. The impeller leading edge is almost parallel with the direction of the flow and leads into the impeller passage. Turbotex pumps are first choice for raw unscreened sewage as well as for lightly contaminated liquids.

#### Pump

solids passage : 110 mm  
 suction diameter : 200 mm  
 discharge diameter : 150 mm  
 impeller diameter : 250 - 210 mm  
 recommended minimum flow : 13 l/s (47 m<sup>3</sup>/h)

#### Motor

rated shaft power : 16.0 kW  
 rated electrical power : 18.8 kW  
 mains : 50 Hz - 3 phase  
 nominal speed : 1450 rpm  
 motor efficiency : 85%  
 rated power factor (cos phi) : 0.78  
 degree of protection : IP 68  
 isolation class : H (180 °C)  
 max. water temperature : 40 °C  
 (higher temp. on request)  
 standard cable length : 10 m

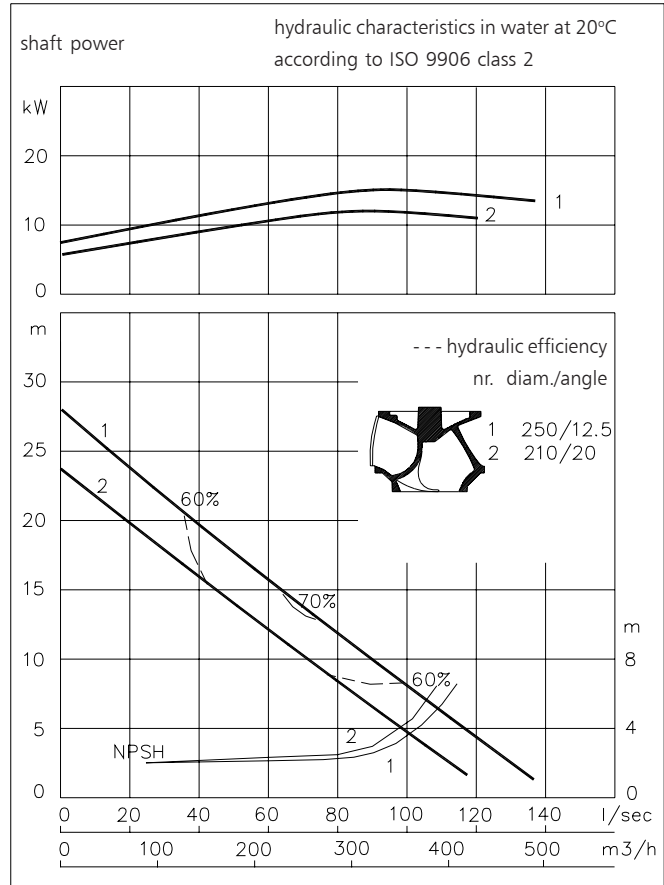

#### Materials

motor housing : 1  
 seal housing : 1  
 volute : 1  
 impeller : 2 7  
 shaft : 3 5  
 bolts : 4 5  
 cooling jacket : 4 5  
 elastomers : 8+9 10  
 electrical cable : 9  
 seal lubrication : oil  
 pump seal : silicon carbide-silicon carbide - viton  
 motor seal : carbon - ceramic  
 primer : Alkyd primer  
 top coating : Two component high-build polyurethane coating

|    |                        |                   |
|----|------------------------|-------------------|
| 1  | cast iron              | EN-GJL-250        |
| 2  | sg cast iron           | EN-GJS-400-15     |
| 3  | stainless steel 431    | X20 CrNi 17 2     |
| 4  | stainless steel 304    | X5 CrNi 18 10     |
| 5  | stainless steel 316    | X5 CrNiMo 17 12 2 |
| 6  | stainless steel 329    | X4 CrNiMoN 27 5 2 |
| 7  | wear resistant sg iron | HB 500            |
| 8  | nitrile                | (NBR)             |
| 9  | neoprene               | (CR)              |
| 10 | viton                  | (FPM)             |

[www.robotpumps.com](http://www.robotpumps.com)

*Engineered for life*



### Installation options

### RT6040LD

**V**  
Guide bar coupling:  
Type V150N

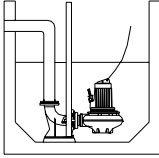

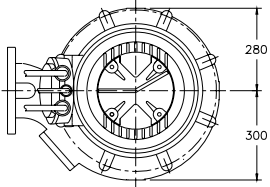

**F**  
Freestanding:  
With support and  
150mm hose adapter

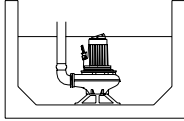

**T**  
Transportable:  
With support and  
150mm hose adapter

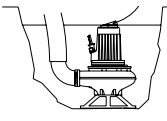

**A**  
Immersible:  
vertical or horizontal  
with cooling system and  
support.  
Discharge: 150mm  
Suction: 200mm

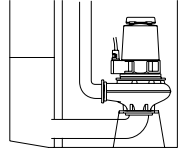

The motor is cooled by the surrounding water.  
With cooling version the motor can run continuously above the waterlevel

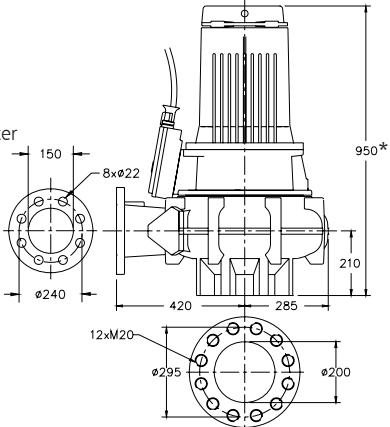

\* version C: 970

### Versions

**B Basic**

Standard with thermostiches

Weight:

330 kg

**E Explosion proof version**

Certified according to: II 2 G Ex de IIB c T4  
Standard with 2 sets of thermostiches.

330 kg

**C Version with cooling system**

Standard with thermostiches  
Internal or external circulation  
(external cooling water min. flow 0.4 l/s)

336 kg

**EC Explosion proof version with cooling system**

Certified according to: II 2 G Ex de IIB c T4

3365 kg

### Optional:

**Flexible protective sheathing for cable**  
(AISI 316)

**Water detector in motor and oil housing**  
(for explosion proof version only in oil housing with external cable)

### Motor connection details

|              |                  | number of cables x number of cores x cross section [mm <sup>2</sup> ] |                   |                         |                   |  |  |
|--------------|------------------|---|-------------------|-------------------------|-------------------|--|--|
| voltage [V]* | rated current[A] |   |                   | explosion proof version |                   |  |  |
|              |                  | DOL-start   | YD-start          | DOL- start              | YD-start          |  |  |
| 220          | 63.3             | 1x4x16 + 1x4x2.5  | 2x4x10 + 1x4x2.5  | 1x4x16 + 1x4x2.5        | 2x4x10+ 1x4x2.5   |  |  |
| 380          | 36.7             | 1x4x10 + 1x4x2.5  | 2x4x4 + 1x4x2.5   | 1x4x10 + 1x4x2.5        | 2x4x4 + 1x4x2.5   |  |  |
| 400          | 34.8             | 1x4x6 + 1x4x2.5   | 1x7x2.5 + 1x4x2.5 | 1x4x6 + 1x4x2.5         | 1x7x2.5 + 1x4x2.5 |  |  |
| 415          | 33.6             | 1x4x6 + 1x4x2.5   | 1x7x2.5 + 1x4x2.5 | 1x4x6 + 1x4x2.5         | 1x7x2.5 + 1x4x2.5 |  |  |
| 500          | 27.9             | 1x4x4 + 1x4x2.5   | 1x7x2.5 + 1x4x2.5 | 1x4x4 + 1x4x2.5         | 1x7x2.5 + 1x4x2.5 |  |  |

starting current DOL start

: 5.4 x rated current

\*other voltages on request

starting current YD-start

: 1.8 x rated current

We reserve the right to alter specifications without prior notice.