



# ITT

## ROBOT PUMPS

### Turbotex Pump

### RT6040LF

60 c/s

Turbotex pumps are auto cleaning solids handling pumps. The impeller leading edge is almost parallel with the direction of the flow and leads into the impeller passage. Turbotex pumps are first choice for raw unscreened sewage as well as for lightly contaminated liquids.

#### Pump

solids passage : 4 1/4"  
 suction diameter : 8"  
 discharge diameter : 6"  
 impeller diameter : 235 - 210  
 recommended minimum flow : 207 USGPM

#### Motor

rated horse power : 33.5 hp  
 rated electrical power : 29.8 kW  
 rated kVA : 36.3 kVA  
 mains : 60 c/s - 3 phase  
 speed : 1750 rpm  
 rated efficiency : 84%  
 rated power factor (cos phi) : 0.82  
 degree of protection : IP 68  
 isolation class : F (311 °F)  
 max. water temperature : 104 °F  
 (higher temperatures on request)  
 standard cable length : 33 ft  
 max. submersion depth : 66 ft

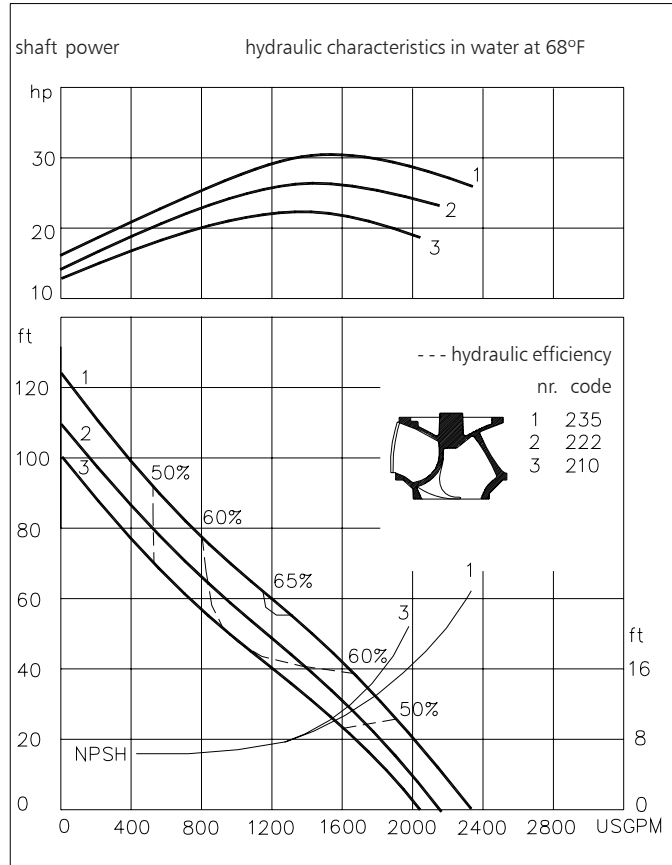

15.9 USGPM = 1 l/s    1 hp = 0.736 kW    1 ft = 0.3 m    1 lb = 0.45 kg

#### Materials

motor housing : 1  
 seal housing : 1 5  
 volute : 1  
 impeller : 2 5 7  
 shaft : 3 5  
 bolts : 4 5  
 cooling jacket : 4 5  
 elastomers : 8+9 10  
 electrical cable : 9  
 seal lubrication : oil  
 pump seal : silicon carbide-silicon carbide  
 motor seal : carbon - ceramic  
 primer : Alkyd primer  
 top coating : Two component high-build polyurethane coating

1	cast iron	ASTM A-48 Cl.35
2	sg cast iron	ASTM A445 Gr.60-46-18
3	stainless steel	AISI 431
4	stainless steel	AISI 304
5	stainless steel	AISI 316
6	bronze	ASTM B 145 Gr. 4a
7	wear resistant sg iron	HB500
8	nitrile	(NBR)
9	neoprene	(CR)
10	viton	(FPM)

www.ittwwwalphen.com

*Engineered for life*



# ITT

## ROBOT PUMPS

### Installation options

### RT6040LF

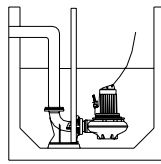

**V**  
Guide bar coupling:  
Type V150N

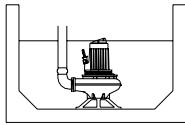
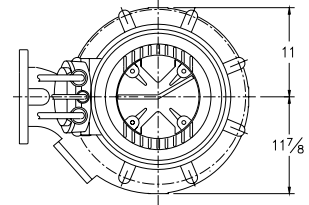

**F**  
Freestanding:  
With support and  
6" hose adapter

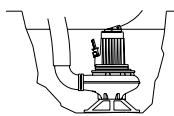

**T**  
Portable:  
With support and  
6" hose adapter

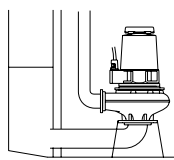

**A**  
Immersible:  
vertical or horizontal  
with cooling system and  
support.  
Discharge: 6"  
Suction: 8"

The motor is cooled by the surrounding water.  
With cooling version the motor can run continuously above the waterlevel

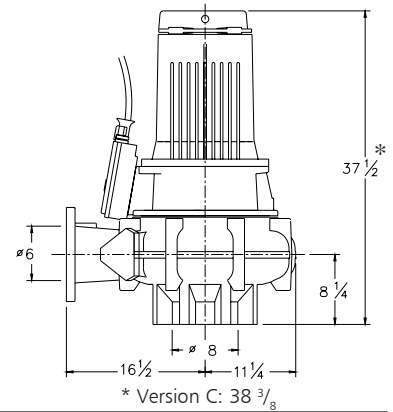

### Versions

### Weight

**B Basic version**

Standard with thermostiches

759 lbs

**P FM approved version**

Certified according to:  
Class I, Division I, Groups C&D T4  
Standard with thermostats and  
waterdetector in motorhousing.

781 lbs

**C Version with cooling system**

Standard with thermostiches  
Internal or external circulation  
(ext. coolingwater min. flow 2.4 USGPM)

772 lbs

### Optional:

**Flexible protective sheating for cable**  
(AISI 316)

**Water detector in motor and oil housing** (for flame proof version only in oil housing with external cable)

### Motor connection details

voltage [V]*	rated curr.[A]	electrical cable size			
		DOL-start		FM approved version	
		DOL-start	YD-start	DOL- start	YD-start
380	55.1	2xAWG 8/4+1xAWG 14/4	2xAWG 8/4+1xAWG 14/4	2xAWG 8/4+1xAWG 14/7	2xAWG 8/4+1xAWG 14/7
440	46.7	1xAWG 6/4+1xAWG 14/4	2xAWG 8/4+1xAWG 14/4	1xAWG 6/4+1xAWG 14/7	2xAWG 8/4+1xAWG 14/7
460	45.6	1xAWG 6/4+1xAWG 14/4	2xAWG 8/4+1xAWG 14/4	1xAWG 6/4+1xAWG 14/7	2xAWG 8/4+1xAWG 14/7
575	36.4	1xAWG 6/4+1xAWG 14/4	2xAWG 10/4+1xAWG 14/4	2xAWG 6/4+1xAWG 14/7	2xAWG 10/4+1xAWG 14/7

starting current DOL start

: 5.7 x rated current

\*other voltages on request

starting current YD-start

: 1.9 x rated current

We reserve the right to alter specifications without prior notice.