



### RoboWhirl

### RM21DC

60 c/s

The RoboWhirl agitators are used to prevent the accumulation of solids and sludge at the bottom of pump sumps and in storm water collecting pits. The turbulence created by the RoboWhirl prevents the formation of a floating crust at the water surface.

#### Mixer

effective working distance : up to Ø20 ft  
 absorbed electrical power in clean water : 1.9 kW  
 impeller code : 105  
 (code Nihard 4 impeller : 138)  
 effective working distance depends on weight- and volume concentration of the solids in the fluid.

#### Motor

rated horse power : 2.3 hp  
 rated electrical power : 2.4 kW  
 rated kVA : 2.8 kVA  
 mains : 60 c/s  
 speed : 1750 rpm  
 rated efficiency : 71 %  
 rated power factor (cos phi) : 0.85  
 degree of protection : IP 68  
 isolation class : F (311 °F)  
 max. water temperature : 104 °F  
 (higher temperatures on request)  
 standard cable length : 33 ft  
 max. submersion depth : 66 ft

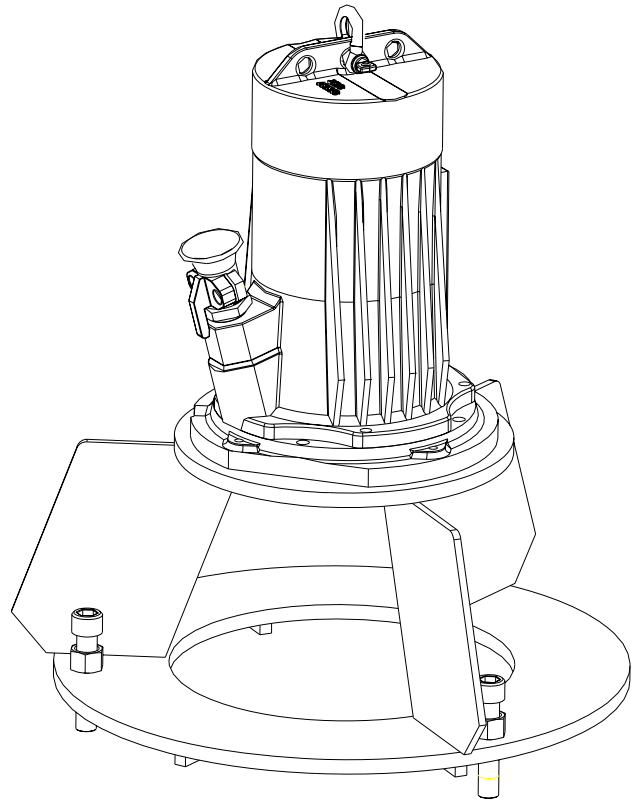

1 ft = 0.3 m    1 lb = 0.45 kg

#### Materials

motor housing : 1  
 seal housing : 1  
 impeller : 2 5 6 7 12  
 shaft : 3 5  
 support : 11 5  
 bolts : 4 5  
 elastomers : 8+9 10  
 electrical cable : 9  
 mechanical seals : oil lubricated  
 pump seal : silicon carbide-silicon carbide  
 motor seal : carbon-ceramic  
 primer : Alkyd primerr  
 top coating : Two component high-build polyurethane coating

1	cast iron	ASTM A-48 Cl.35
2	sg cast iron	ASTM A445 Gr.60-46-18
3	stainless steel	AISI 431
4	stainless steel	AISI 304
5	stainless steel	AISI 316
6	bronze	ASTM B 145 Gr. 4a
7	wear resistant sg iron	HB500
8	nitrile	(NBR)
9	neoprene	(CR)
10	viton	(FPM)
11	galvanized steel	
12	Nihard 4	HRc 56,HB 555



### Dimensions

### RM21DC

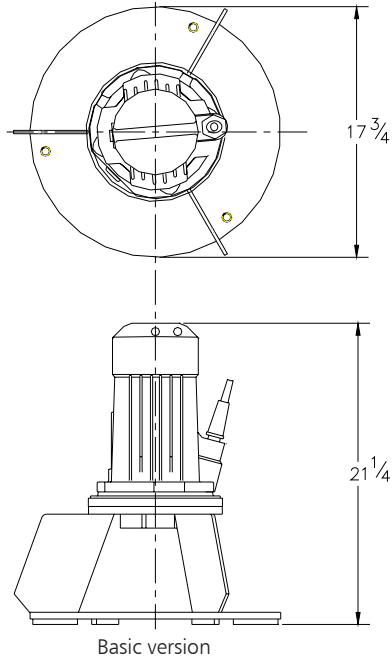

Basic version

The motor is cooled by the surrounding water.

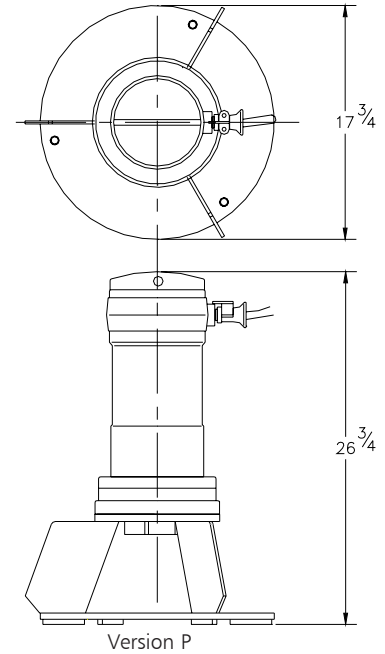

Version P

### Versions

**B Basic version**

**Weight**

92 lbs

**P FM approved version**

118 lbs

Certified according to:  
Class I, Division I, Groups C&D T4

**N Wear resistant version**

100 lbs

Impeller and wear plate in Nihard 4

**PN FM approved and  
Wear resistant version**

126 lbs

Certified according to:  
Class I, Division I, Groups C&D T4

### Optional:

**Thermoswitches** in motorwindings  
Standard for FM approved version

**Flexible protective sheathing for cable**  
(AISI 316)

**Water detector in motor and oil housing** (For FM approved version standard in motorhousing. In oil housing with external cable)

### Connection details

voltage [V]*	rated current[A]	electrical cable size					
		DOL-start		with waterdetector and/or thermoswitches		FM approved version	
220	7.4	1xAWG16/4		1xAWG16/7		1xAWG14/8	
380	4.3	1xAWG16/4		1xAWG16/7		1xAWG14/8	
440	3.6	1xAWG16/4		1xAWG16/7		1xAWG14/8	
460	3.5	1xAWG16/4		1xAWG16/7		1xAWG14/8	
575	2.8	1xAWG16/4		1xAWG16/7		1xAWG14/8	

starting current DOL-start : 4.8 x rated current

\* other voltages on request

We reserve the right to alter specifications without prior notice