





# ITT

## ROBOT PUMPS

### Installation options

### RC2215BB

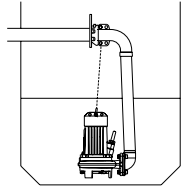

**H**  
Header coupling:  
Type HK65 or HK80

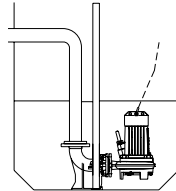

**V**  
Guide bar coupling:  
Type V65-N

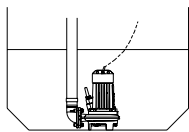
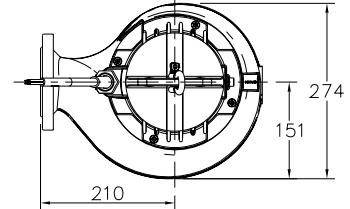

**F**  
Freestanding:  
With 75mm hose adapter  
or R2.5" or R3" threaded  
connection

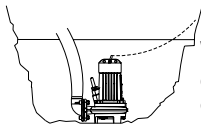

**T**  
With 75mm hose adapter  
or R2.5" or R3" threaded  
connection

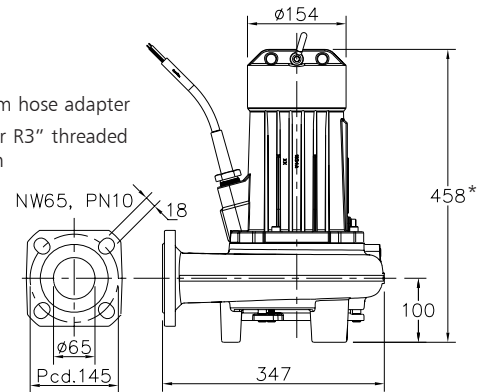

The motor is cooled by the surrounding water.

\* version E: 558

Version	Weight
<b>B Basic</b>	44 kg
<b>E Explosion proof version</b> Certified according to: II 2 G Ex de IIB c T4	51 kg

**Optional:**

- Thermoswitches** in motorwindings  
Standard for explosion proof version (2 sets)
- Flexible protective sheathing for cable**  
(AISI 316)
- Water detector** in motor and oil housing  
(for explosion proof version only in oil housing with external cable)

### Motor connection details

voltage [V]*	rated current[A]	number of cables x number of cores x cross section [mm <sup>2</sup> ]					
		DOL-start		with waterdetector and/or thermoswitches		explosion proof version	
220	6.1	1x4x1.5		1x7x1.5		1x7x2.5	
380	3.5	1x4x1.5		1x7x1.5		1x7x2.5	
400	3.3	1x4x1.5		1x7x1.5		1x7x2.5	
415	3.2	1x4x1.5		1x7x1.5		1x7x2.5	
500	2.7	1x4x1.5		1x7x1.5		1x7x2.5	

starting current DOL-start

: 4.8 x rated current

\* other voltages on request

We reserve the right to alter specifications without prior notice.