



ITT

ROBOT PUMPS

Channel pump

RC2215AK-M

50 Hz

The channel impeller pumps are designed to pump lightly contaminated waste water at high efficiencies. RC pumps are equipped with an open channel impeller running against an adjustable suction cover.
Excellent for drainage or leakage water.

Pump

3 channels
solids passage : 30 mm
suction diameter : 80 mm
discharge diameter : 65 mm
impeller diameter : 68 mm
recommended minimum flow : 2 l/s (8 m³/h)

Motor

rated shaft power : 1.2 kW
rated electrical power : 1.5 kW
mains : 50 Hz - 1 phase
speed : 2900 rpm
motor efficiency : 70 %
rated power factor (cos phi) : 0.87
degree of protection : IP 68
isolation class : F (155 °C)
max. water temperature : 40 °C
(higher temp. on request)
standard cable length : 10 m

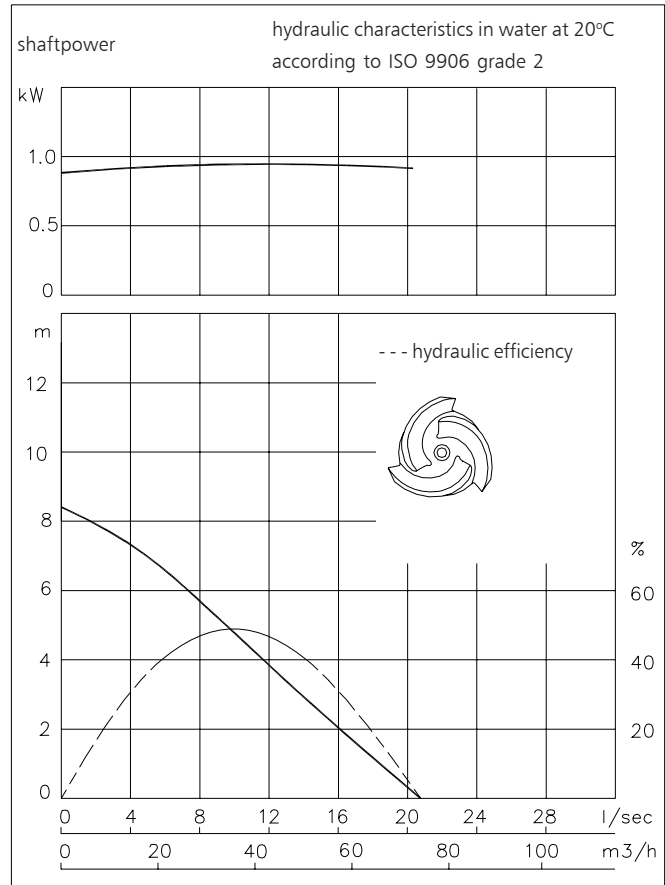

Pump curves are for cast iron only.

Materials

motor housing : 1
seal housing : 1
volute : 1
impeller : 1
suction cover : 1
shaft : 3 5
bolts : 4 5
elastomers : 8+9 10
electrical cable : 9
mechanical seals : oil lubricated
pump seal : silicon carbide-silicon carbide
motor seal : carbon-ceramic
primer : Alkyd primer
top coating : Two component high-build polyurethane coating

1	cast iron	EN-GJL-250
2	sg cast iron	EN-GJS-400-15
3	stainless steel 431	X20 CrNi 17 2
4	stainless steel 304	X5 CrNi 18 10
5	stainless steel 316	X5 CrNiMo 17 12 2
6	stainless steel 329	X4 CrNiMoN 27 5 2
7	wear resistant sg iron	HB 500
8	nitrile	(NBR)
9	neoprene	(CR)
10	viton	(FPM)

www.ittwwwalphen.com

Engineered for life



ITT

ROBOT PUMPS

Installation options

RC2215AK-M

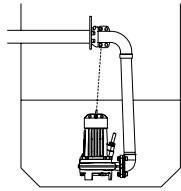

H

Header coupling:
Type HK65 or HK80

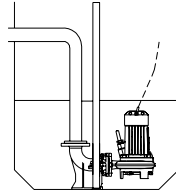

V

Guide bar coupling:
Type V65-N

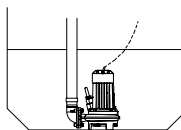
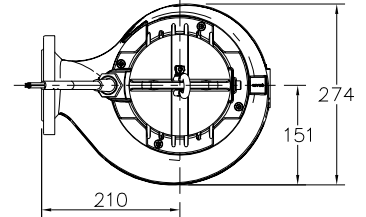

F

Freestanding:
With 75mm hose adapter
or R2.5" or R3" threaded
connection

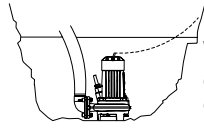

T

With 75mm hose adapter
or R2.5" or R3" threaded
connection

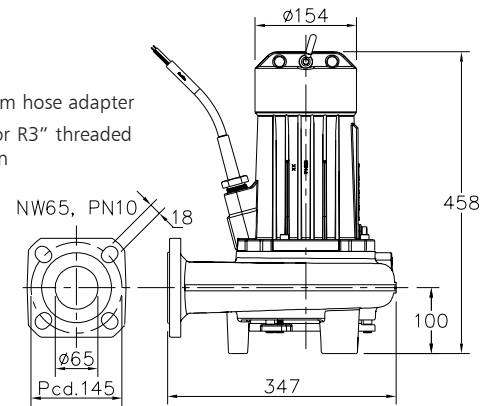

The motor is cooled by the surrounding water.

Version

Weight

B Basic

Standard with thermostiches

44 kg

Optional:

Flexible protective sheathing for cable
(AISI 316)

Water detector in motor and oil housing

Motor connection details

voltage [V]*	rated current[A]	number of cables x number of cores x cross section [mm ²]				
		with waterdetector and/or thermostiches				
		DOL-start	run/start capacitor			
220	8.9	1x7x1.5	35/60 µF/450V			
230	8.5	1x7x1.5	35/60 µF/450V			
240	8.1	1x7x1.5	35/60 µF/450V			

starting current

: 4.4 x rated current

* other voltages on request

We reserve the right to alter specifications without prior notice.