



ITT

ROBOT PUMPS

Slurry Pump

RD4030DJ

60 c/s

Vortex impeller pump in wear resistant Nihard 4 for reliable transport of highly abrasive solids in high concentrations.

Pump

solids passage : 3"
 solids passage with agitator : 1 1/4"
 suction diameter : 4"
 discharge diameter : 4"
 impeller diameter : 190
 recommended minimum flow : 95 USGPM

Motor

rated horse power : 7.8 hp
 rated electrical power : 7.4 kW
 rated kVA : 9.0 kVA
 mains : 60 c/s - 3 phase
 speed : 1750 rpm
 rated efficiency : 79 %
 rated power factor (cos phi) : 0.85
 degree of protection : IP 68
 isolation class : F (311 °F)
 max. water temperature : 104 °F
 (higher temperatures on request)
 standard cable length : 33 ft
 max. submersion depth : 66 ft

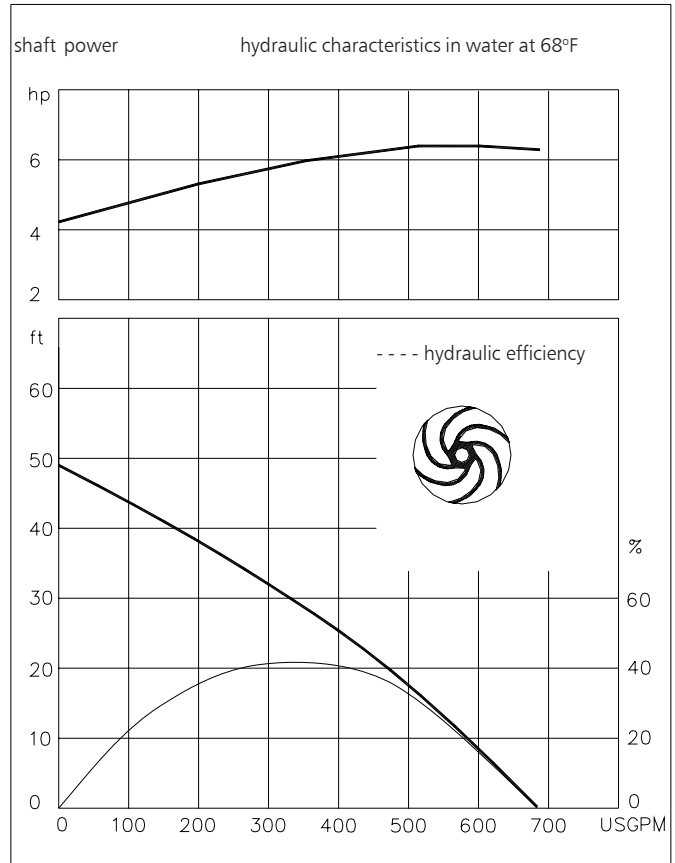

15.9 USGPM = 1 l/s 1 hp = 0.736 kW 1 ft = 0.3 m 1 lb = 0.45 kg

Materials

motor housing : 1
 seal housing : 7
 volute : 7
 hose adapter : 7
 impeller : 7
 agitator : 7
 shaft : 3 5
 bolts : 4 5
 cooling jacket : 5
 elastomers : 8+9 10
 electrical cable : 9
 seal lubrication : oil
 pump seal : silicon carbide-silicon carbide
 motor seal : carbon-ceramic
 primer : Alkyd primer
 top coating : Two component high-build polyurethane coating

1	cast iron	ASTM A-48 Class 35
2	sg cast iron	ASTM A445 Gr.60-46-18
3	stainless steel	AISI 431
4	stainless steel	AISI 304
5	stainless steel	AISI 316
6	bronze	ASTM B145 Gr. 4a
7	Nihard 4	ASTM A532, class I, type D
8	nitrile	(NBR)
9	neoprene	(CR)
10	viton	(FPM)

www.ittwwwalphen.com

Engineered for life



Installation options

RD4030DJ

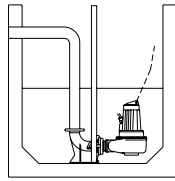

V
Guide bar coupling:
Type V100

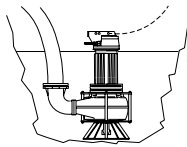

T
Transportable:
With support and
4" discharge bend.

Without cooling system the motor is cooled by the surrounding water.
With cooling system the motor can run continuously above the water level.

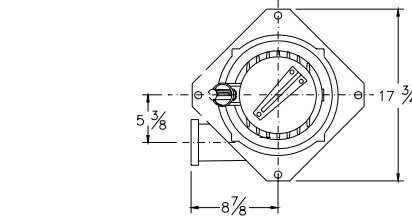

Fig. 1 Basic version
Installation V

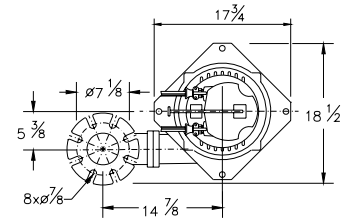
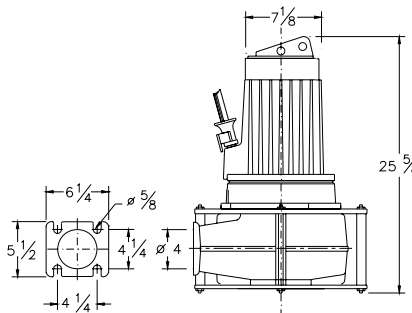
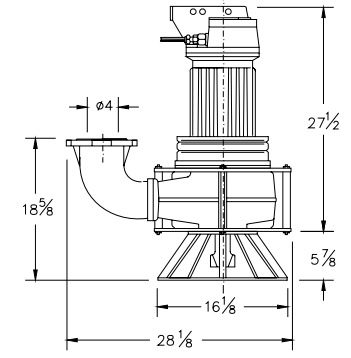

Fig. 2 Version K/P
Installation T



Versions

B Basic version (Fig. 1)

K Basic version (Fig. 2)
Standard with thermoswitches,
agitator and cable connection box.

P FM approved version
Certified according to:
Class I, Division I, Groups C&D T4
Standard with thermostats and
waterdetector in motorhousing.

Weight

239 lbs

360 lbs

360 lbs

Optional:

Cooling system external cooling water flow min. 2.4 USGPM, not possible for flameproof version

Flexible protective sheating for cable
(AISI 316)

Water detector in motor and oil housing (for explosion proof version only in oil housing with external cable)

Motor connection details

voltage [V]*	rated current[A]	electrical cable size					
				with waterdetector and/or thermoswitches		FM approved version	
		DOL-start	YD-start	DOL-start	YD-start	DOL-start	YD-start
220	22.8	1xAWG10/4	1xAWG14/7	1xAWG10/4+1xAWG14/4**	1xAWG14/7+1xAWG14/4**	1xAWG10/4+1xAWG14/7	2xAWG14/7
380	13.2	1xAWG14/4	1xAWG14/7	1xAWG14/7	1xAWG16/10***	1xAWG12/4+1xAWG14/7	2xAWG14/7
440	11.4	1xAWG14/4	1xAWG14/7	1xAWG14/7	1xAWG16/10***	1xAWG12/4+1xAWG14/7	2xAWG14/7
460	10.9	1xAWG14/4	1xAWG14/7	1xAWG14/7	1xAWG16/10***	1xAWG12/4+1xAWG14/7	2xAWG14/7
575	8.7	1xAWG14/4	1xAWG14/7	1xAWG14/7	1xAWG16/10***	1xAWG12/4+1xAWG14/7	2xAWG14/7

starting current DOL-start : 5.0 x rated current

starting current YD-start : 1.7 x rated current

* other voltages on request **not possible for basic version

*** version C and RC:1xAWG14/7 + 1xAWG14/4

We reserve the right to alter specifications without prior notice.