



ITT

ROBOT PUMPS

Slurry Pump

RD4030DZ

60 c/s

Vortex impeller pump in wear resistant Nihard 4 for reliable transport of highly abrasive solids in high concentrations.

Pump

solids passage : 3"
 solids passage with agitator : 1 1/4"
 suction diameter : 4"
 discharge diameter : 4"
 impeller diameter : 230
 recommended minimum flow : 95 USGPM

Motor

rated horse power : 20.0 hp
 rated electrical power : 17.5 kW
 rated kVA : 20.8 kW
 mains : 60 c/s - 3 phase
 speed : 1750 rpm
 rated efficiency : 85 %
 rated power factor (cos phi) : 0.84
 degree of protection : IP 68
 isolation class : F (311 °F)
 max. water temperature : 104 °F
 (higher temperatures on request)
 standard cable length : 33 ft
 max. submersion depth : 66 ft

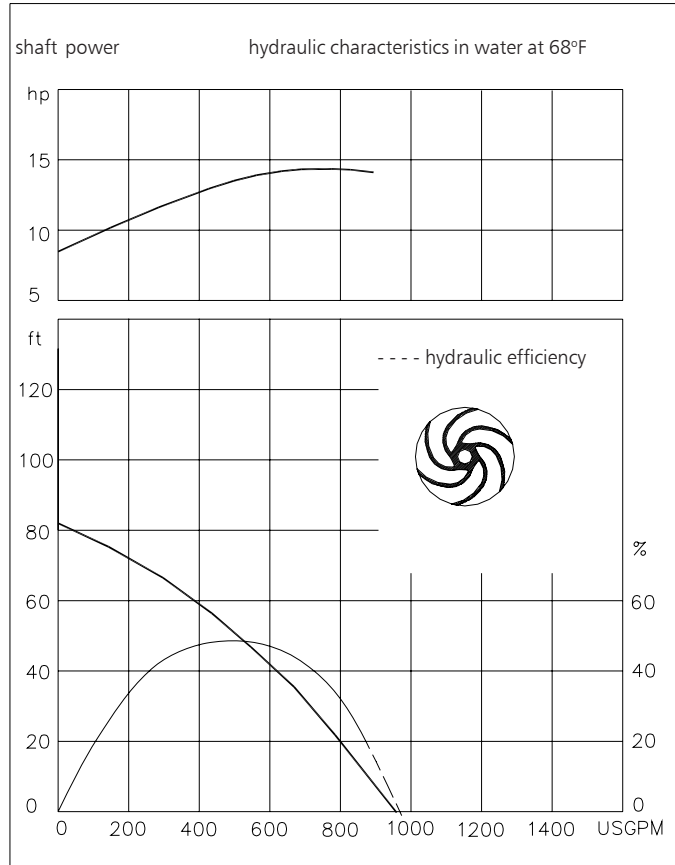

15.9 USGPM = 1 l/s 1 hp = 0.736 kW 1 ft = 0.3 m 1 lb = 0.45 kg

Materials

motor housing : 1
 seal housing : 7
 volute : 7
 hose adapter : 7
 impeller : 7
 agitator : 7
 shaft : 3 5
 bolts : 4 5
 cooling jacket : 5
 elastomers : 8+9 10
 electrical cable : 9
 seal lubrication : oil
 pump seal : silicon carbide-silicon carbide
 motor seal : carbon-ceramic
 primer : Alkyd primer
 top coating : Two component high-build polyurethane coating

1	cast iron	ASTM A-48 Class 35
2	sg cast iron	ASTM A445 Gr.60-46-18
3	stainless steel	AISI 431
4	stainless steel	AISI 304
5	stainless steel	AISI 316
6	bronze	ASTM B145 Gr. 4a
7	Nihard 4	ASTM A532, class I, type D
8	nitrile	(NBR)
9	neoprene	(CR)
10	viton	(FPM)

www.ittwwwalphen.com

Engineered for life



ITT

ROBOT PUMPS

Installation options

RD4030DZ

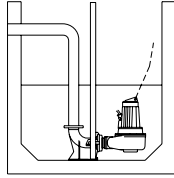

V

Guide bar coupling:
Type V100

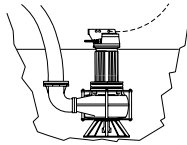
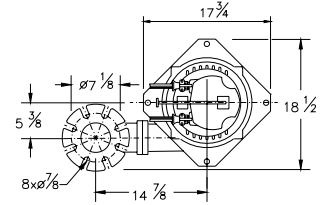
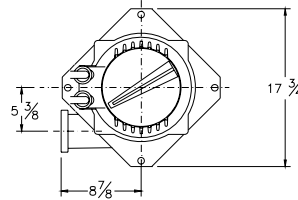

T

Transportable:
With support and
4" discharge bend.

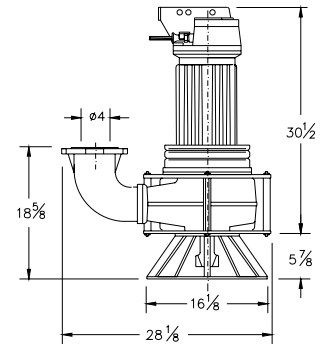
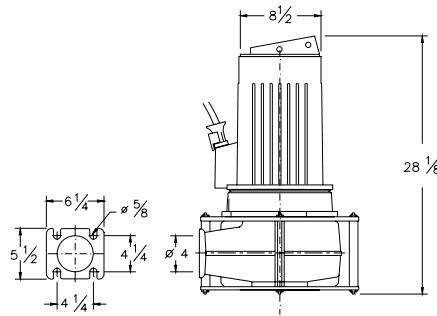

Fig. 1 Basic version

Installation V

Fig. 2 Version K/P

Installation T

Without coolingsystem the motor is cooled by the surrounding water.
With coolingsystem the motor can run continuously above the water level.

Versions

B Basic version (Fig. 1)

K Basic version (Fig. 2)

Standard with themoswitches, agitator and cable connection box.

P FM approved version

Certified according to:
Class I, Division I, Groups C&D T4
Standard with thermostats and waterdetector in motorhousing.

Weight

288 lbs

371 lbs

371 lbs

Optional:

Cooling system external cooling water flow min. 2.4 USGPM, not possible for flameproof version

Flexible protective sheating for cable (AISI 316)

Water detector in motor and oil housing (for explosion proof version only in oil housing with external cable)

Motor connection details

voltage [V]*	rated current[A]	electrical cable size					
				with waterdetector and/or thermostiches		FM approved version	
		DOL-start	YD-start	DOL-start	YD-start	DOL-start	YD-start
220	55.1	2xAWG8/4	2xAWG8/4	-	-	-	-
380	31.9	1xAWG8/4	1xAWG12/7	1xAWG8/4+1xAWG14/4	-	1xAWG8/4+1xAWG14/7	-
440	27.5	1xAWG8/4	1xAWG12/7	1xAWG8/4+1xAWG14/4	-	1xAWG8/4+1xAWG14/7	-
460	26.3	1xAWG8/4	1xAWG12/7	1xAWG8/4+1xAWG14/4	-	1xAWG8/4+1xAWG14/7	-
575	21.1	1xAWG10/4	1xAWG16/7	1xAWG10/4+1xAWG14/4	1xAWG14/7+1xAWG14/4	1xAWG10/4+1xAWG14/7	2xAWG14/7

starting current DOL-start : 5.0 x rated current

starting current YD-start : 1.7 x rated current

* other voltages on request

We reserve the right to alter specifications without prior notice.