



ITT

ROBOT PUMPS

Dry installed vortex pump

BW4041

The dry installed vortex pumps are designed to pump a wide variety of solids contaminated liquids. They are used for sewage and other waste water applications. These pumps are designed for a stationary dry installation of pump and motor.

solids passage : 100 mm **50 Hz**
 discharge flange : NW 100
 suction flange : NW 125
 impeller diameter : 252-200 mm
 recommended min. flow : 6 l/s (21 m³/h)

hydraulic characteristics in clean cold water according to ISO 9906 grade 2

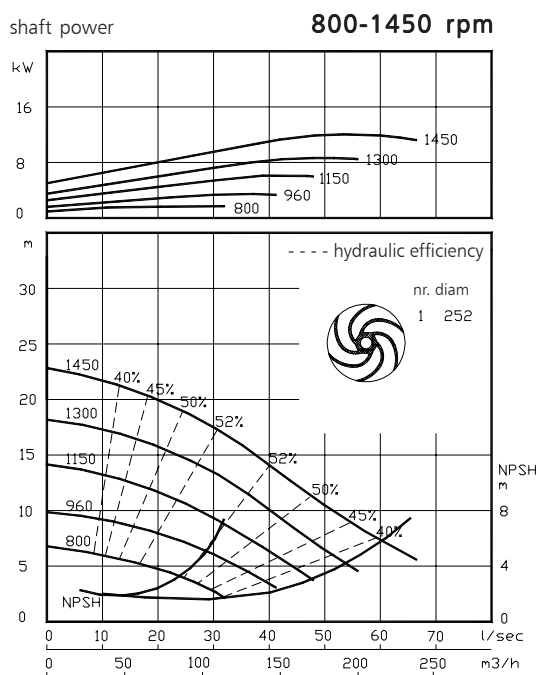
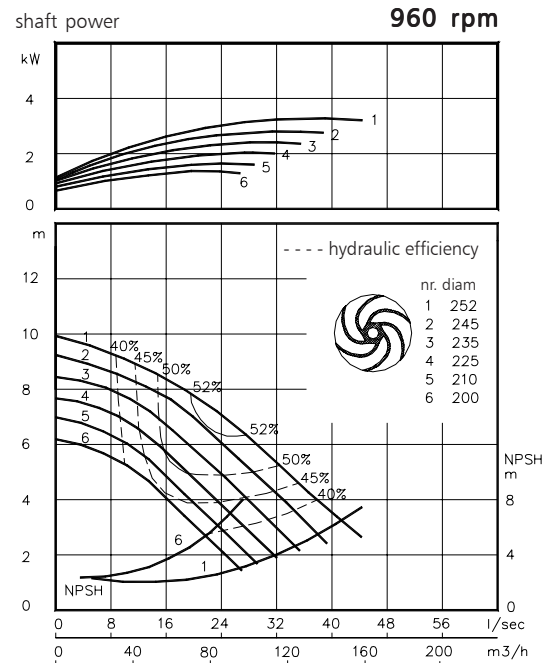
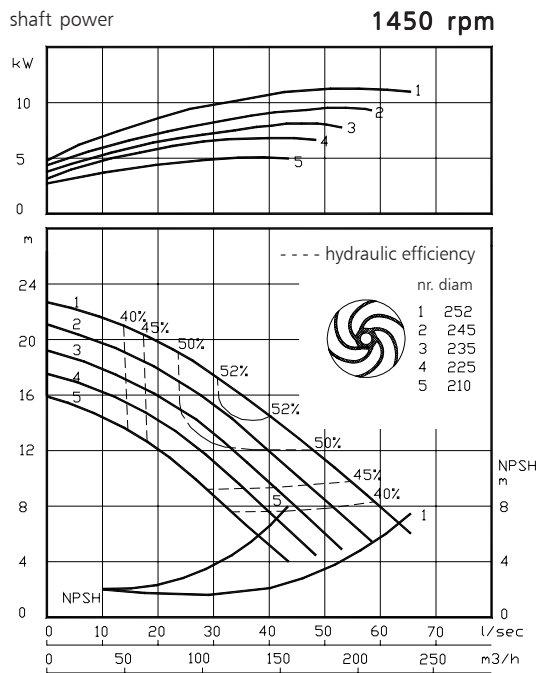

Available electric motors Degree of protection IP55		
Class	kW	[rpm]
IEC 132S	3.0	960
	5.5	1450
IEC 132M	4.0	960
	5.5	960
	7.5	1450
IEC 160M	11.0	1450
IEC 160L	15.0	1450

www.robotpumps.com

Engineered for life



ITT

ROBOT PUMPS

Installation options

BW4041

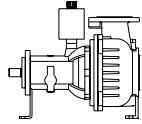

H

Horizontal installation:
Bare shaft

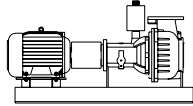

HM

Horizontal installation:
With foundation plate
and electric motor.

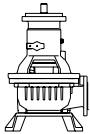

V

Vertical installation:
Bare shaft



VM

Vertical installation:
With support and electric
motor.

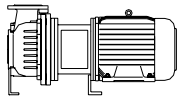

HS

Short coupled:
Horizontal installation.

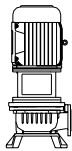

VS

Short coupled:
Vertical installation.

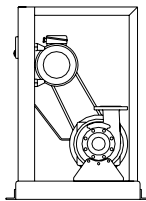

K

V-belt driven:
Frame construction.
For motors IEC100L-200L.

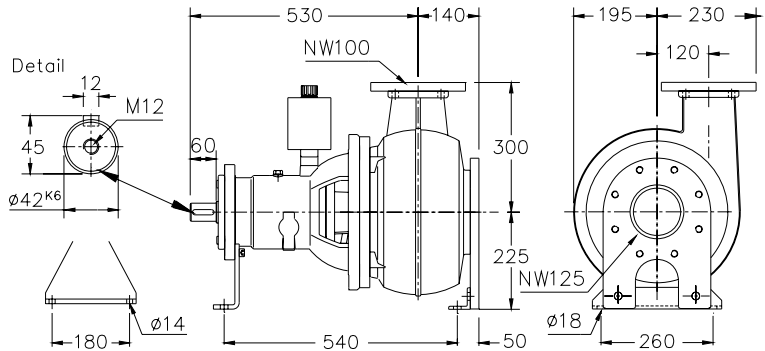

Flange connections

		Standard	
		DIN 2501	PN10/PN16
		p.c.d.	Number of holes
Discharge	NW 100	180	8x ϕ 19
Suction	NW 125	210	8x M16

Weight (H version): 115 kg.

Optional:

- seal flushing

Other options and materials upon request

Materials

sealhousing	: 1
pump casing	: 1
impeller	: 2 5 6 7
pump shaft	: 3 5
bearing housing	: 1
bolts	: 4 5
elastomer	: 8+9 10
seal lubrication	: oil
pump seal	: silicon carbide-silicon carbide
secondary seal	: carbon - ceramic
primer	: alkyd primer
top coating	: two components high-build polyurethane coating

1	cast iron	EN-GJL-250
2	sg cast iron	EN-GJS-400-15
3	stainless steel 431	X20 CrNi 17 2
4	stainless steel 304	X5 CrNi 18 10
5	stainless steel 316	X5 CrNiMo 17 12 2
6	stainless steel 329	X4 CrNiMoN 27 5 2
7	wear resistant sg iron	HB 500
8	nitrile	(NBR)
9	neoprene	(CR)
10	viton	(FPM)

We reserve the right to alter specifications without prior notice.