



ITT

ROBOT PUMPS

Dry Installed Vortex Pump

BW4021

The dry installed vortex pumps are designed to pump a wide variety of solids contaminated liquids. They are used for sewage and other waste water applications. These pumps are designed for a stationary dry installation of pump and motor.

solids passage : 2 1/2" **60 c/s**
 discharge flange : 3"
 suction flange : 3"
 impeller code : 178 - 140
 recommended minium flow : 55 USGPM

hydraulic characteristics in water at 68°F

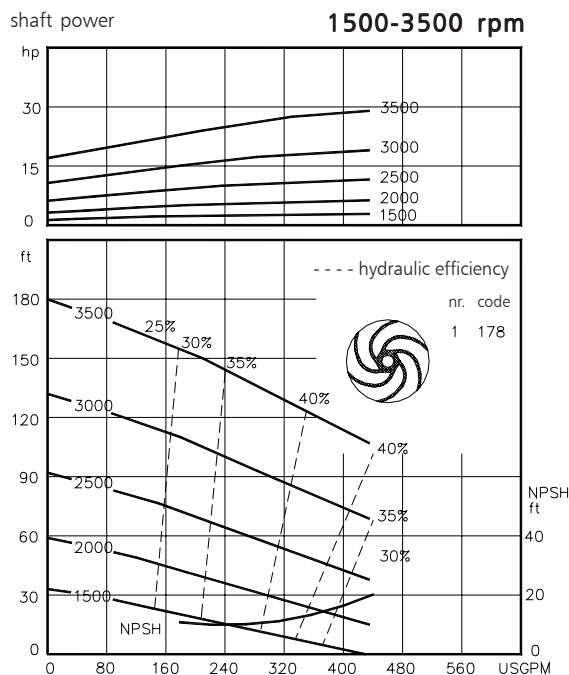
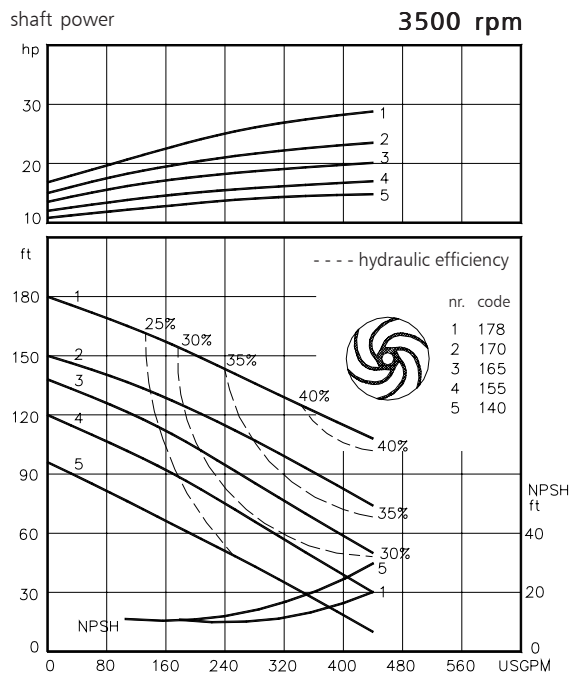

Available electric motors Degree of protection IP55		
NEMA	[hp]	[rpm]
215T	15	3500
254T	20	3500
256T	25	3500
284TS	30	3500

www.ittwwwalphen.com

Engineered for life



ITT

ROBOT PUMPS

Installation options

BW4021

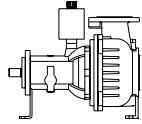

H

Horizontal installation:
Bare shaft

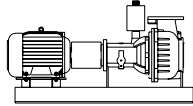

HM

Horizontal installation:
With foundation plate
and electric motor.



V

Vertical installation:
Bare shaft

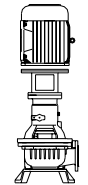

VM

Vertical installation:
With support and electric
motor.

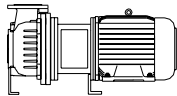

HS

Short coupled:
Horizontal installation.

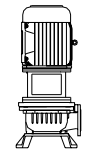

VS

Short coupled:
Vertical installation.

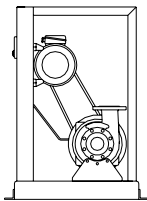

K

V-belt driven:
Frame construction.
For motors NEMA
145T - 324T.

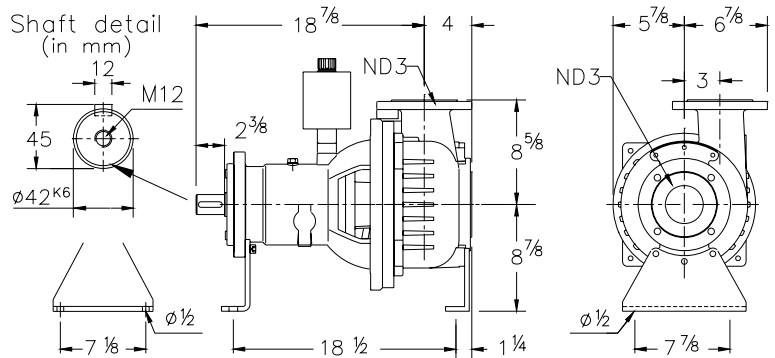

Flange connections

Standard

		p.c.d.	ANSI 150 Number x holes
Discharge	ND 3	6	4 x $\varnothing \frac{3}{4}$
Suction	ND 3	6	4 x $\frac{5}{8}$ UNC

Weight (H version): 220 lbs

Optional:

- seal flushing

Other options and materials upon request

Materials

sealhousing	: 1
pump casing	: 1
impeller	: 2 5 6
pump shaft	: 3 5
bearing housing	: 1
bolts	: 4 5
elastomer	: 8+9 10
seal lubrication	: oil
pump seal	: silicon carbide-silicon carbide
secondary seal	: carbon - ceramic
primer	: Alkyd primer
top coating	: Two component high-build polyurethane coating

1	cast iron	ASTM A-48 Cl.35
2	sg cast iron	ASTM A445 Gr.60-46-18
3	stainless steel	AISI 431
4	stainless steel	AISI 304
5	stainless steel	AISI 316
6	stainless steel	AISI 329
7	wear resistant sg iron	HB500
8	nitrile	(NBR)
9	neoprene	(CR)
10	viton	(FPM)

We reserve the right to alter specifications without prior notice.