



ITT

ROBOT PUMPS

Dry Installed Vortex Pump

BW4040

The dry installed vortex pumps are designed to pump a wide variety of solids contaminated liquids. They are used for sewage and other waste water applications. These pumps are designed for a stationary dry installation of pump and motor.

solids passage : 4" **60 c/s**
 discharge flange : 4"
 suction flange : 4"
 impeller code : 250-165
 recommended minium flow : 95 USGPM

hydraulic characteristics in water at 68°F

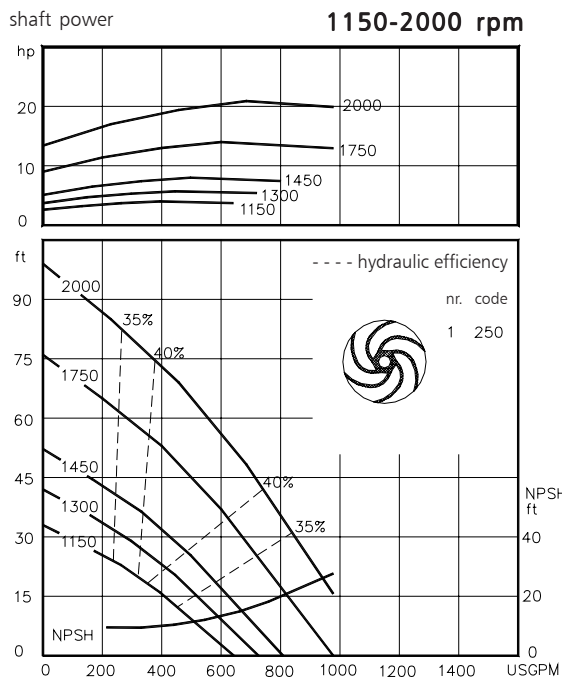
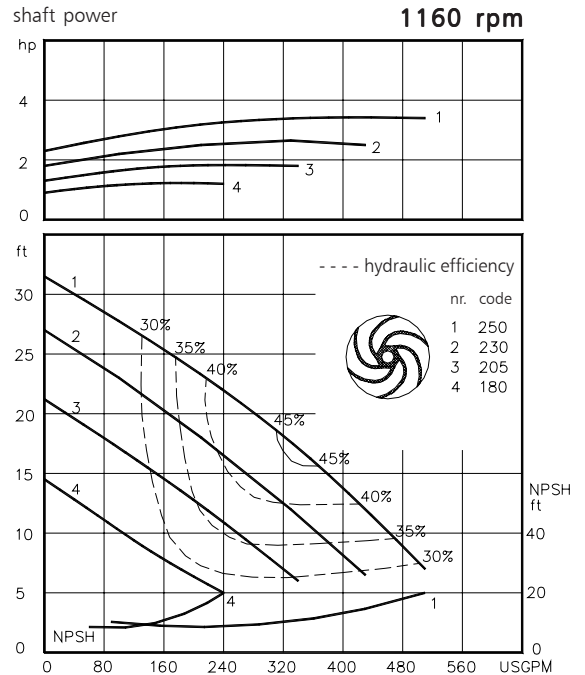
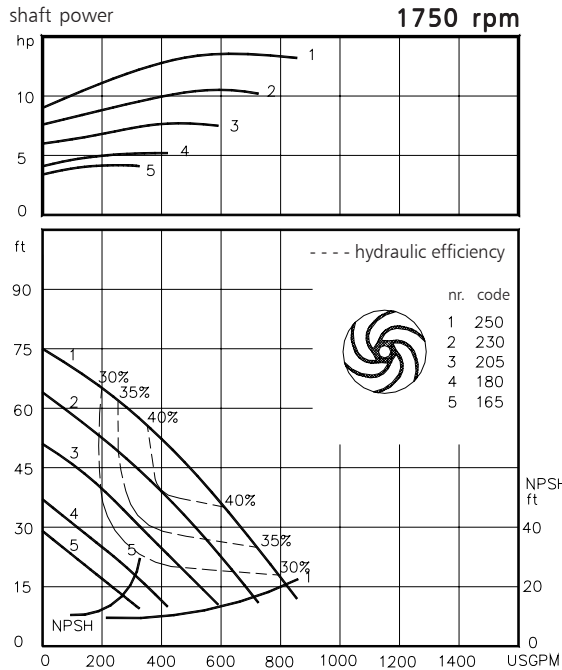

Available electric motors Degree of protection IP55		
NEMA	[hp]	[rpm]
184T	2.0	1160
213T	3.0	1160
215T	5.0	1160
213T	7.5	1750
215T	10	1750
254T	15	1750
215T	15	3500
254T	20	3500
256T	25	3500
284TS	30	3500

www.itwwwalphen.com

Engineered for life



ITT

ROBOT PUMPS

Installation options

BW4040



H

Horizontal installation:
Bare shaft

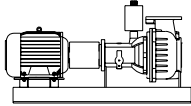

HM

Horizontal installation:
With foundation plate
and electric motor.



V

Vertical installation:
Bare shaft

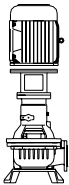

VM

Vertical installation:
With support and electric
motor.

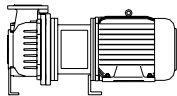

HS

Short coupled:
Horizontal installation.

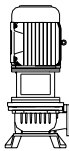

VS

Short coupled:
Vertical installation.

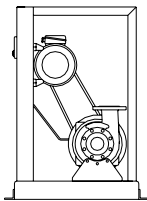

K

V-belt driven:
Frame construction.
For motors NEMA
145T - 324T.

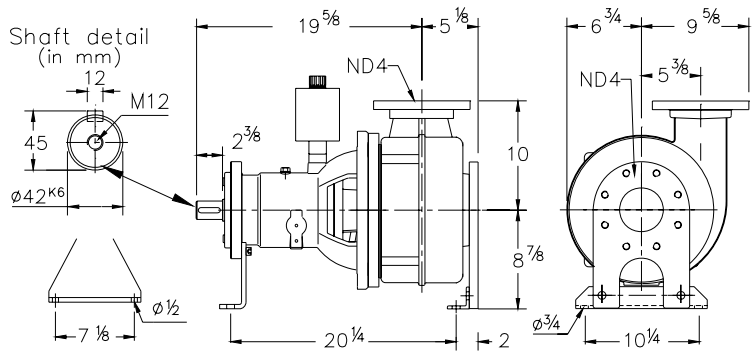

Flange connections

Standard

		p.c.d.	ANSI 150 Number x holes
Discharge	ND 4	7 1/2	8 x φ 3/4
Suction	ND 4	7 1/2	8 x 5/8 UNC

Weight (H version): 242 lbs

Optional:

- seal flushing

Other options and materials upon request

Materials

sealhousing	: 1
pump casing	: 1
impeller	: 2 5 6 7
pump shaft	: 3 5
bearing housing	: 1
bolts	: 4 5
elastomer	: 8+9 10
seal lubrication	: oil
pump seal	: silicon carbide-silicon carbide
secondary seal	: carbon - ceramic
primer	: Alkyd primer
top coating	: Two component high-build polyurethane coating

1	cast iron	ASTM A-48 Cl.35
2	sg cast iron	ASTM A445 Gr.60-46-18
3	stainless steel	AISI 431
4	stainless steel	AISI 304
5	stainless steel	AISI 316
6	stainless steel	AISI 329
7	wear resistant sg iron	HB500
8	nitrile	(NBR)
9	neoprene	(CR)
10	viton	(FPM)

We reserve the right to alter specifications without prior notice.