



# ITT

## ROBOT PUMPS

### BT - Turbotex Pump

### BT6040

BT pumps are designed to pump sewage and other kinds of waste water in many different applications. These pumps are equally suitable for clean water or lightly contaminated liquids. They are designed for a stationary dry installation of pump and motor.

solids passage : 110 mm **50 Hz**  
 discharge flange : NW 150  
 suction flange : NW 200  
 impeller diameter : 300-210 mm  
 recommended min. flow : 13 l/s (47 m<sup>3</sup>/h)

hydraulic characteristics in clean cold water according to ISO 9906 grade 2

shaft power **1450 rpm**

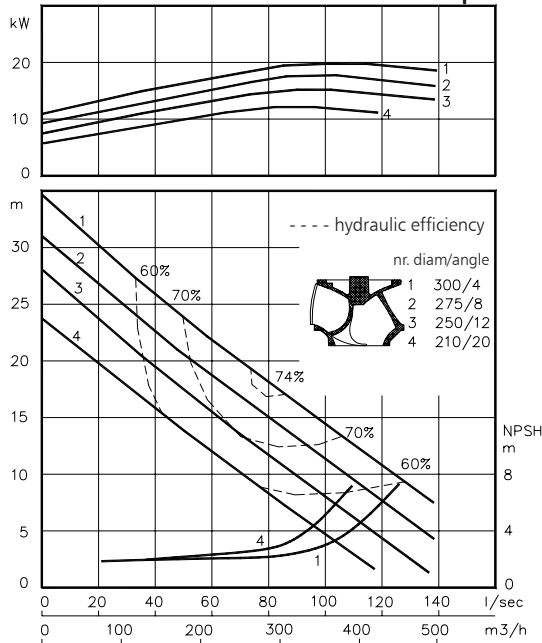

shaft power **960 rpm**

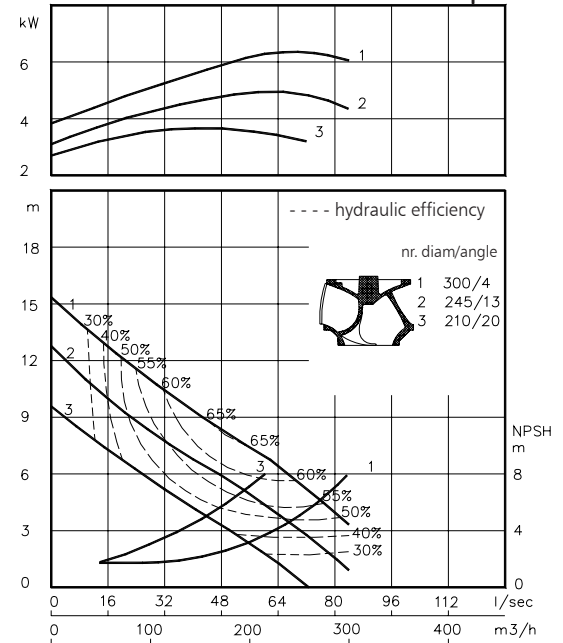

shaft power **800-1450 rpm**

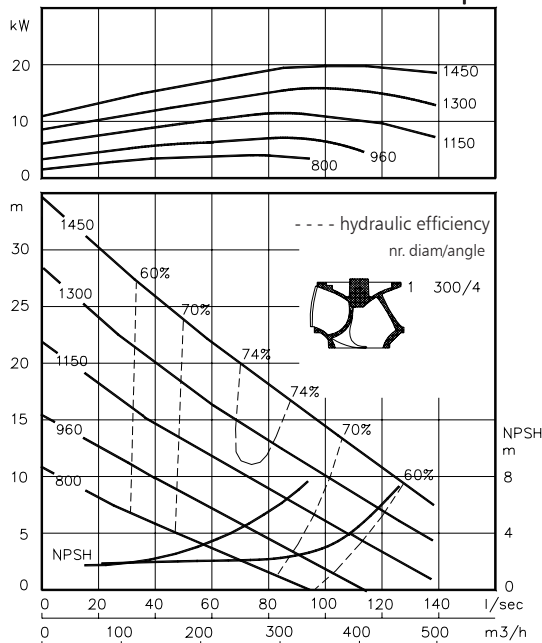

Available electric motors Degree of protection IP55		
Class	kW	[rpm]
IEC 132S	3.0	960
	5.5	1450
IEC 132M	4.0	960
	5.5	960
	7.5	1450
IEC 160M	11.0	1450
IEC 160L	15.0	1450
IEC 180M	18.5	1450
IEC 180L	22	1450

[www.ittwwwalphen.com](http://www.ittwwwalphen.com)

*Engineered for life*



# ITT

## ROBOT PUMPS

### Installation options

### BT6040

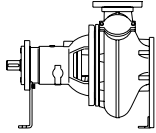

**H**

Horizontal installation:  
Bare shaft

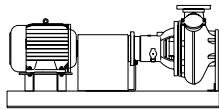

**HM**

Horizontal installation:  
With foundation plate  
and electric motor.

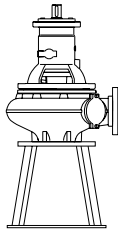
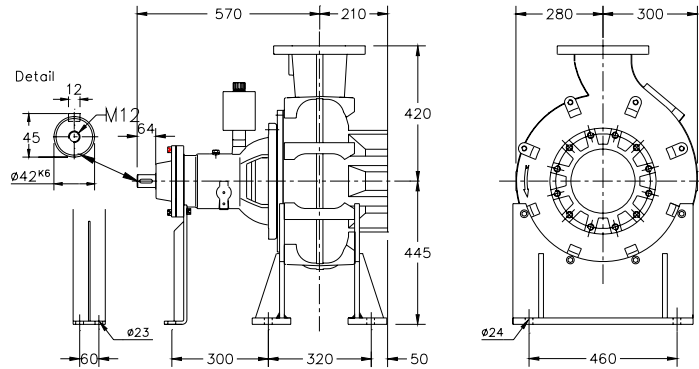

**V**

Vertical installation:  
Bare shaft

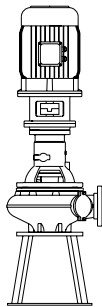

**VM**

Vertical installation:  
With support and electric  
motor.

#### Flange connections

	Standard	
	DIN 2501 PN10/PN16	
	p.c.d.	Number of holes
Discharge	NW 150 240	8x ø23
Suction	NW 200 295	12x M20

Weight (H version): 270 kg.

#### Optional:

- seal flushing

*Other options and materials upon request*

### Materials

sealhousing	: 1
pump casing	: 1
impeller	: 2 7
pump shaft	: 3 5
bearing housing	: 1
bolts	: 4 5
elastomer	: 8+9 10
seal lubrication	: oil
pump seal	: silicon carbide-silicon carbide
secondary seal	: carbon - ceramic
primer	: alkyd primer
coating	: two components high-build polyurethane coating

1	cast iron	EN-GJL-250
2	sg cast iron	EN-GJS-400-15
3	stainless steel 431	X20 CrNi 17 2
4	stainless steel 304	X5 CrNi 18 10
5	stainless steel 316	X5 CrNiMo 17 12 2
6	stainless steel 329	X4 CrNiMoN 27 5 2
7	wear resistant sg iron	HB 500
8	nitrile	(NBR)
9	neoprene	(CR)
10	viton	(FPM)

We reserve the right to alter specifications without prior notice.