



# ITT

## ROBOT PUMPS

### Channel pump

### RC2215BE

### 60 Hz

The channel impeller pumps are designed to pump lightly contaminated waste water at high efficiencies. RC pumps are equipped with an open channel impeller running against an adjustable suction cover. Excellent for drainage or leakage water.

**Pump** 3 channels  
 solids passage : 1<sup>3</sup>/<sub>16</sub>"  
 suction diameter : 3<sup>1</sup>/<sub>8</sub>"  
 discharge diameter : 2<sup>1</sup>/<sub>2</sub>"  
 impeller code : 78  
 recommended minimum flow : 30 USGPM

**Motor**  
 rated horse power : 4.0 hp  
 rated electrical power : 4.0 kW  
 rated kVA : 4.4 kVA  
 mains : 60 c/s - 3 phase  
 speed : 3500 rpm  
 rated efficiency : 75 %  
 rated power factor (cos phi) : 0.90  
 degree of protection : IP 68  
 isolation class : F (311 °F)  
 max. water temperature : 104 °F  
 (higher temperatures on request)  
 standard cable length : 33 ft  
 max. submersion depth : 66 ft

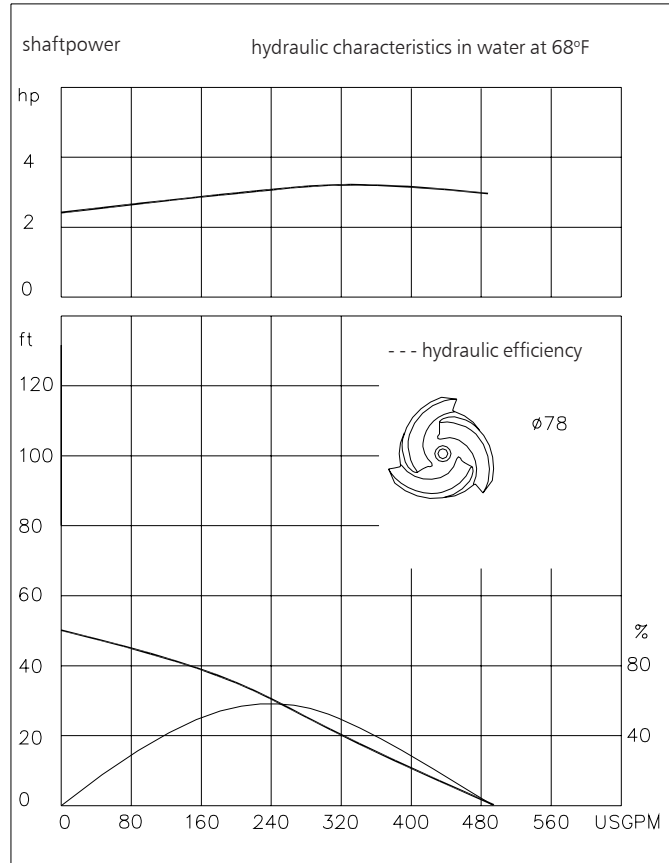

15.9 USGPM = 1 l/s 1 hp = 0.746 kW 1 ft = 0.3 m 1 lb = 0.45 kg

### Materials

motor housing : 1  
 seal housing : 1  
 volute : 1  
 impeller : 1 5  
 suction cover : 1  
 shaft : 3 5  
 bolts : 4 5  
 elastomers : 8+9 10  
 electrical cable : 9  
 mechanical seals : oil lubricated  
 pump seal : silicon carbide-silicon carbide  
 motor seal : carbon-ceramic

1	cast iron	ASTM A-48 Cl.35
2	sg cast iron	ASTM A445 Gr.60-46-18
3	stainless steel	AISI 431
4	stainless steel	AISI 304
5	stainless steel	AISI 316
6	stainless steel	AISI 329
7	wear resistant sg iron	HB500
8	nitrile	(NBR)
9	chlorinated polyethylene	(CPE)
10	viton	(FPM)

[www.ittwalphen.com](http://www.ittwalphen.com)

*Engineered for life*



### Installation options

### RC2215BE

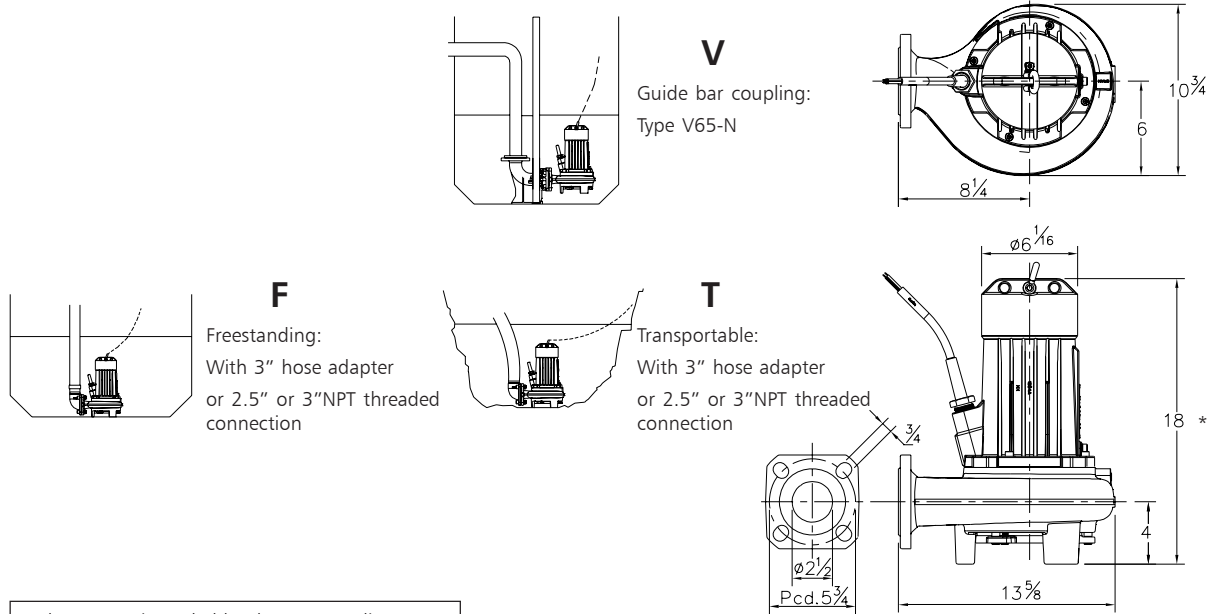

The motor is cooled by the surrounding water.

\* version P: 21<sup>5</sup>/<sub>8</sub>"

#### Version

#### Weight

<b>B Basic</b>	113 lbs
<b>P FM approved version</b> Certified according to: Class I, Division I, Groups C&D T4 Standard with thermostiches	129 lbs

#### Optional:

**Thermostiches** in motorwindings

**Flexible protective sheating for cable**  
(AISI 316)

**Water detector** in motor and oil housing

### Motor connection details

voltage [V]*	rated current[A]	electrical cable size					
		DOL-start		with waterdetector and/or thermostiches		FM approved version	
220	11.7	14 AWG/4		14 AWG/7		S3x2.5+4x1.5	
380	6.8	14 AWG/4		14 AWG/7		S3x2.5+4x1.5	
440	5.9	14 AWG/4		14 AWG/7		S3x2.5+4x1.5	
460	5.6	14 AWG/4		14 AWG/7		S3x2.5+4x1.5	
575	4.5	14 AWG/4		14 AWG/7		S3x2.5+4x1.5	

starting current DOL-start : 4.6 x rated current

\* other voltages on request

starting current YD-start : 1.5 x rated current

We reserve the right to alter specifications without prior notice.