

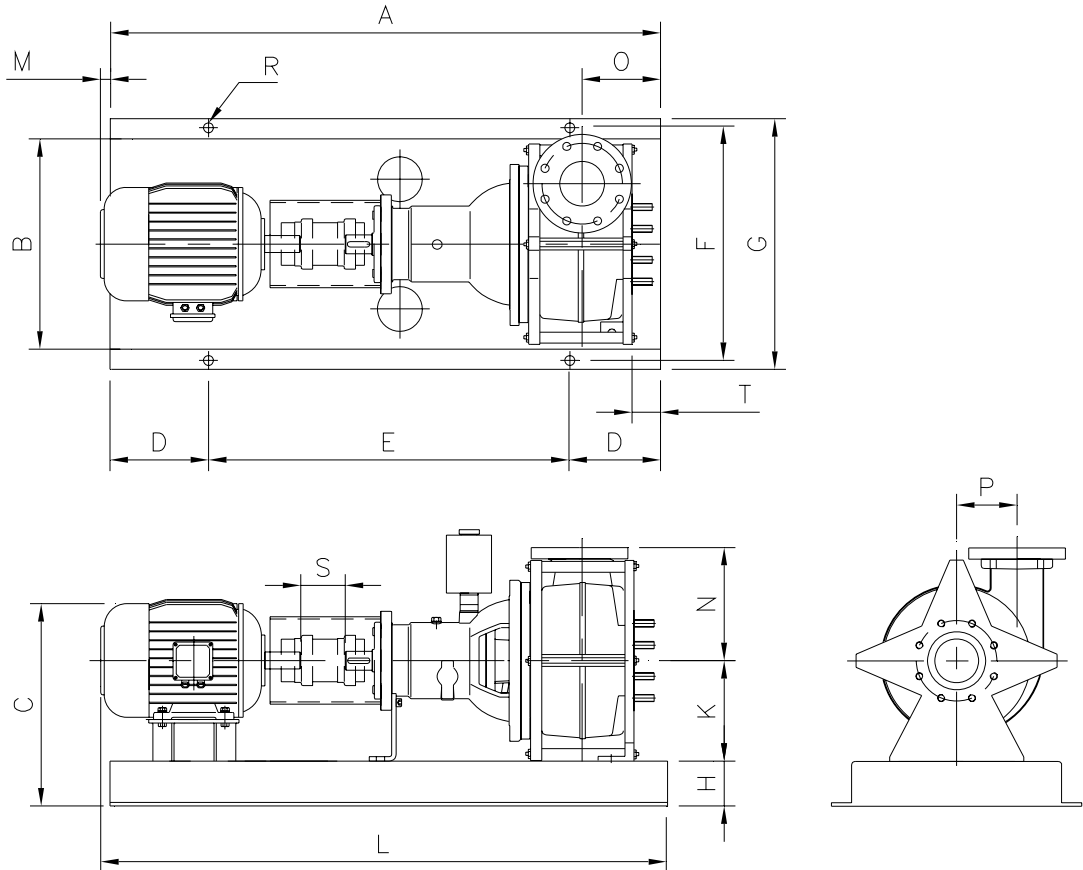

### Technische Information

### Abmessungen BD-HM



<b>BD4030-HM</b>																	
Motor Baugröße	A	B	C	D	E	F	G	H	K	L	M	N	O	P	R	S	T
132 S	1250	560	464	205	840	620	670	110	225	1285	35	255	165	135	4xø22	140	0
132 M	1250	560	464	205	840	620	670	110	225	1320	70	255	165	135	4xø22	140	0
160 M	1400	625	491	230	940	685	735	110	225	1425	25	255	165	135	4xø22	140	0
160 L	1400	625	491	230	940	685	735	110	225	1470	70	255	165	135	4xø22	140	0
<b>BD4041-HM</b>																	
132 S	1250	560	464	205	840	620	670	110	225	1325	75	310	185	120	4xø22	140	0
132 M	1400	625	464	230	940	685	735	110	225	1360	-	310	185	120	4xø22	140	0
160 M	1400	625	491	230	940	685	735	110	225	1465	65	310	185	120	4xø22	140	0
160 L	1400	625	491	230	940	685	735	110	225	1510	110	310	185	120	4xø22	140	0
<b>BD6040-HM</b>																	
160 M	1400	625	491	230	940	685	735	110	225	1445	45	305	180	165	4xø22	140	0
160 L	1400	625	491	230	940	685	735	110	225	1490	90	305	180	165	4xø22	140	0
180 M	1400	665	509	230	940	685	735	110	225	1470	70	305	180	165	4xø22	140	0
180 L	1400	665	509	230	940	685	735	110	225	1510	110	305	180	165	4xø22	140	0
200 L	1600	675	528	330	940	735	785	110	225	1605	5	305	180	165	4xø22	140	0
225 S	1600	675	552	330	940	735	785	110	225	1640	40	305	180	165	4xø22	140	0
225 M	1600	675	552	330	940	735	785	110	225	1665	40	305	180	165	4xø22	140	0